

IP [English] Dimensions
SI (Metric) in Parentheses

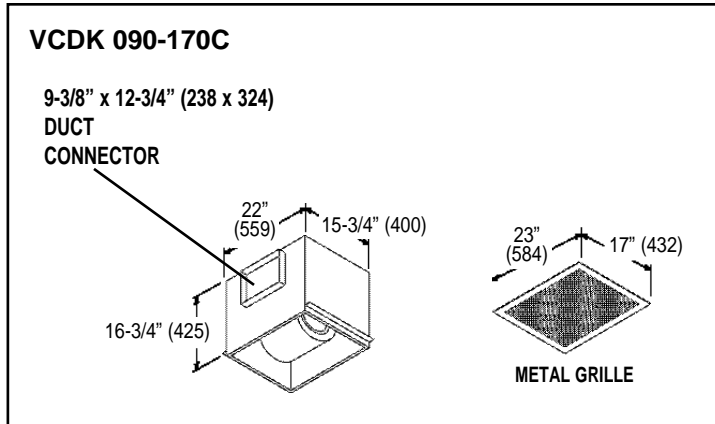

CARNES COMPANY 448 S. Main St., P. O. Box 930040, Verona, WI 53593-0040 Phone: (608)845-6411 Fax: (608)845-6504 www.carnes.com



Models VCDK 090C-170C

- 120 VAC.
- 9-3/8" x 12-3/4" (238 x 324) duct connector.
- Sturdy, low profile metal grille finished with white enamel.

Models VCDK 090I-170I

- 120 VAC.
- Two 9-3/8" x 12-3/4" (238 x 324) duct connectors.
- Removable access panel.
- Single impact resistant blower.

FAN LOCATION	QTY	MODEL/SIZE	CFM	SP	FAN RPM	SONES	MOTOR			ACCESSORIES
							HP	ELECTRICAL	TYPE	

PROJECT:			ARCHITECT		
CONTACTOR:	DATE:	SUBMITTED BY	ENGINEER		