

▼ **Electronic Thermostat**

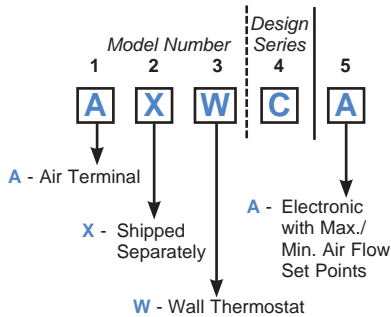

A Carnes Electronic Thermostat **must be ordered** with the ET Electronic Control Option.

▼ **Direct Digital Control (DD/DC/DM)**

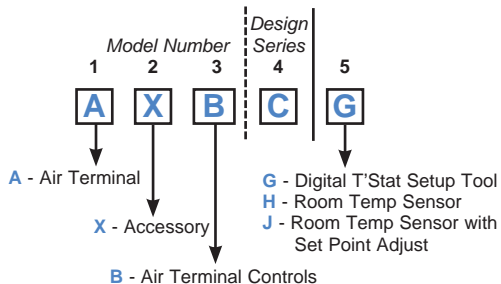

* Electronic and DDC Units **DO NOT** fail open. '1' or '2' is used for Right or Left Hand Only. Electronic Units are shipped with the Damper in the Open Position.