

Application

High capacity unit with low sound levels, suitable for large spaces where no discharge adjustment is required.

Standard Features

- Available in heavy gauge steel or aluminum construction.
- Aluminum available through size 18 only.
- Core is easily removed for installation or maintenance.
- Neck sizes 4" through 36".
- Neck is sized to fit over duct for minimum air leakage.
- Discharge is fixed horizontal setting.
- Center button is removable for easy access to damper.
- Standard finish is Carnes electrocoat acrylic baked enamel. Other finishes are available upon request.
- The standard color is #11 bright white. Other colors are available on request.

Optional Features

- Safety chain (Option S) prevents damage or injury when removing core by connecting the core to the form.
- Gasket (Option G) minimizes air leaks around edge of diffuser.
- Sizes 14" and smaller can be set in a 24"x24" T-bar panel (Option T) for easier installation (p. A21).

Accessories

- When specifying damper for sizes 4-24, use opposed blade round damper model KXRA (p. A427).
- When specifying damper for sizes 28-36, use radial deflector damper model KXNA (p. A430).

Quick Select Chart

This shows units with: • A maximum NC/RC of 35.
• A minimum face velocity of 400 FPM.

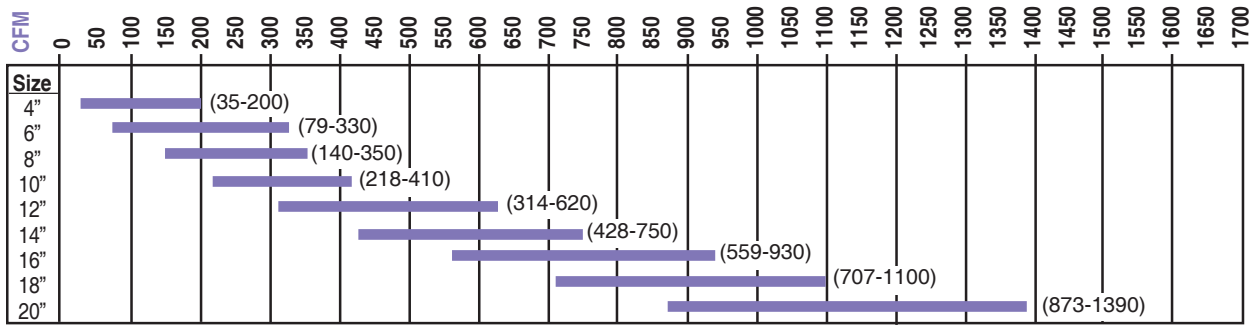

Model Numbering System

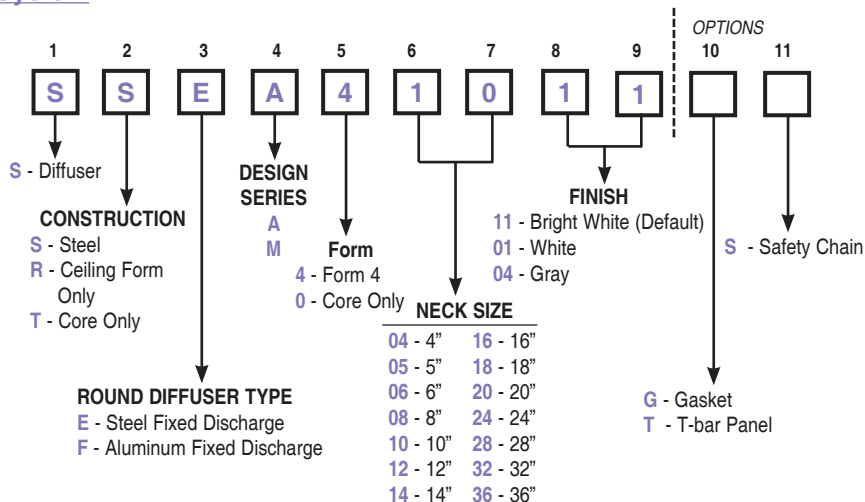

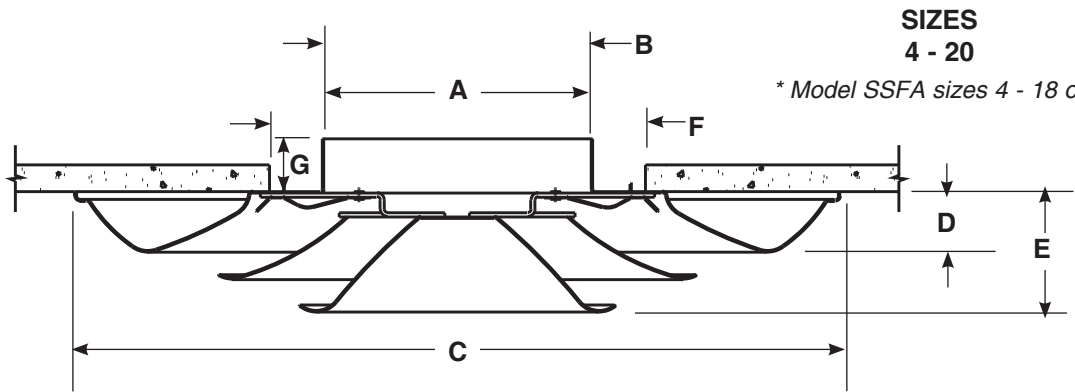

**SIZES
4 - 20**

* Model SSFA sizes 4 - 18 only.

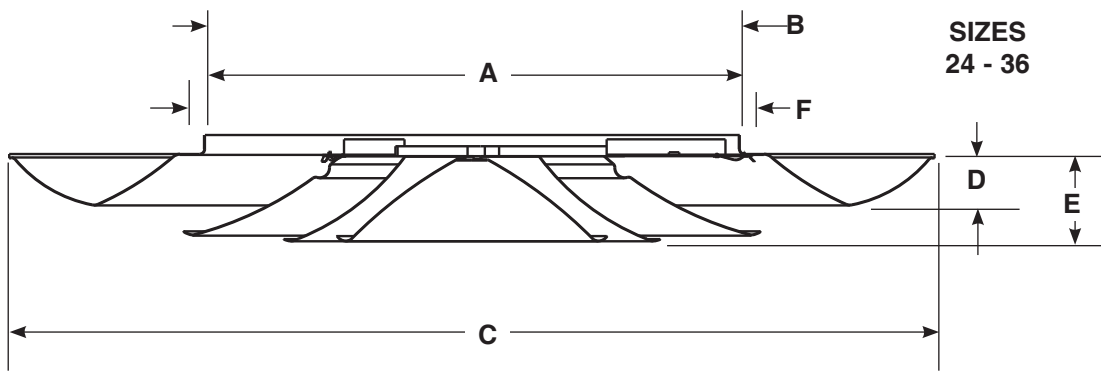

**SIZES
24 - 36**

Dim	Description	Neck Size (Dimensions In Inches)							
		4	5	6	8	10	12	14	
A	Neck I.D.	4-1/16	5-1/16	6-1/16	8-1/16	10-1/16	12-1/16	14-1/16	
B	Neck O.D.	4-1/8	5-1/8	6-1/8	8-1/8	10-1/8	12-1/8	14-1/8	
C	Frame O.D.	14-1/2	14-1/2	14-1/2	17-9/16	19-13/16	22-1/16	24-1/16	
D	Form Projection	1-3/16	1-3/16	1-3/16	1-3/8	1-3/8	1-3/8	1-1/2	
E	Overall Projection	1-15/16	1-15/16	1-15/16	2-3/8	1-7/8	2-5/16	2-5/16	
F	Rec. Ceiling Opening	7-1/4	7-1/4	7-1/4	9-1/4	11-1/4	13-1/4	15-1/4	
G	Collar Height	3/4	1-3/8	1	1	1	1	1	

Dim	Description	Neck Size (Dimensions In Inches)							
		16	18	20	24	28	32	36	
A	Neck I.D.	16-1/16	18-1/16	20-1/16	24-1/16	28-1/16	32-1/16	36-1/16	
B	Neck O.D.	16-1/8	18-1/8	20-1/8	24-1/8	28-1/8	32-1/8	36-1/8	
C	Frame O.D.	28-13/16	32-1/16	33-9/16	39-5/16	48-9/16	60-13/16	60-13/16	
D	Form Projection	2-1/8	2-1/8	2-1/4	2-5/8	2-11/16	2-7/8	2-7/8	
E	Overall Projection	2-3/4	3-1/8	3-1/8	3-11/16	4-1/2	4-15/16	4-15/16	
F	Rec. Ceiling Opening	17-1/4	19-1/4	21-1/4	25-1/4	29-1/4	33-1/4	37-1/4	
G	Collar Height	1	1	1	1	1	1	1	

Notes:

1. The neck is sized to fit over the duct so as to minimize air leakage.

Neck Velocity (FPM)	200	400	600	800	1000	1200	1400	1600
Velocity Pressure (w.g.)	0.003	0.010	0.022	0.040	0.062	0.090	0.122	0.160
Air Flow (CFM)	17	35	52	70	87	105	122	140
4" Total Pressure (w.g.)	0.005	0.02	0.05	0.09	0.14	0.20	0.27	0.36
Sound Level (NC/RC)	-- / --	-- / --	-- / --	13/12H	17/15H	18/17H	20/19H	21/21H
Radius of Diffusion (ft.)	1-1-2	1-1-3	2-2-4	2-3-5	3-4-7	3-5-8	4-5-9	5-6-11
Air Flow (CFM)	27	55	82	109	136	164	191	218
5" Total Pressure (w.g.)	0.01	0.03	0.07	0.11	0.17	0.24	0.32	0.42
Sound Level (NC/RC)	-- / --	-- / --	14/11H	17/16H	19/19H	22/22H	24/24H	27/26H
Radius of Diffusion (ft.)	1-1-2	1-2-3	2-3-5	3-4-6	3-5-8	4-6-9	5-7-11	6-8-13
Air Flow (CFM)	39	79	118	157	196	236	275	314
6" Total Pressure (w.g.)	0.01	0.04	0.08	0.13	0.20	0.28	0.38	0.48
Sound Level (NC/RC)	-- / --	13/10H	17/16H	21/21H	23/23H	28/27H	30/29H	32/31H
Radius of Diffusion (ft.)	1-1-2	1-2-4	2-3-6	3-5-8	4-6-10	5-7-12	6-8-13	7-9-16
Air Flow (CFM)	70	140	209	279	349	419	489	559
8" Total Pressure (w.g.)	0.01	0.03	0.07	0.12	0.18	0.27	0.37	0.48
Sound Level (NC/RC)	-- / --	19/19H	27/26H	31/30H	34/33H	38/37H	42/40H	44/42H
Radius of Diffusion (ft.)	1-1-3	2-3-5	3-4-8	4-6-10	5-7-13	7-9-15	8-11-18	9-12-20
Air Flow (CFM)	109	218	327	436	545	654	764	873
10" Total Pressure (w.g.)	0.01	0.06	0.12	0.24	0.36	0.52	0.72	0.96
Sound Level (NC/RC)	-- / --	21/23H	30/31H	37/37H	42/42H	47/47N	50/50N	52/53N
Radius of Diffusion (ft.)	1-2-3	2-3-6	4-5-10	5-7-13	7-9-16	8-11-19	10-13-22	11-15-25
Air Flow (CFM)	157	314	471	628	785	942	1100	1257
12" Total Pressure (w.g.)	0.01	0.04	0.10	0.20	0.37	0.49	0.67	0.88
Sound Level (NC/RC)	-- / --	24/25H	31/32H	36/37H	42/43N	48/48N	51/51N	54/54N
Radius of Diffusion (ft.)	1-2-4	3-4-8	4-6-11	6-9-15	8-11-19	9-13-22	11-16-26	13-18-30
Air Flow (CFM)	214	428	641	855	1069	1283	1497	1710
14" Total Pressure (w.g.)	0.02	0.05	0.11	0.20	0.31	0.44	0.59	0.78
Sound Level (NC/RC)	-- / --	25/26H	32/32H	38/38N	43/43N	48/48N	52/52N	55/55N
Radius of Diffusion (ft.)	2-2-4	3-5-9	5-7-13	7-10-17	9-13-22	11-16-26	13-18-30	15-21-34
Air Flow (CFM)	279	559	838	1117	1396	1676	1955	2234
16" Total Pressure (w.g.)	0.01	0.07	0.14	0.26	0.41	0.59	0.82	1.06
Sound Level (NC/RC)	-- / --	26/27H	33/33N	39/39N	44/44N	49/49N	52/52N	56/56N
Radius of Diffusion (ft.)	2-3-5	4-6-10	6-9-15	8-12-20	10-15-25	13-18-29	15-21-35	17-24-39
Air Flow (CFM)	353	707	1060	1414	1767	2121	2474	2827
18" Total Pressure (w.g.)	0.01	0.05	0.11	0.22	0.35	0.53	0.72	0.96
Sound Level (NC/RC)	-- / --	27/27H	34/34N	39/39N	44/44N	49/49N	53/53N	56/56N
Radius of Diffusion (ft.)	2-3-6	4-6-11	7-10-17	9-13-22	11-16-27	14-20-33	17-23-38	19-27-44
Air Flow (CFM)	436	873	1309	1745	2182	2618	3054	3491
20" Total Pressure (w.g.)	0.01	0.05	0.12	0.24	0.36	0.54	0.76	1.00
Sound Level (NC/RC)	-- / --	27/28N	34/34N	39/39N	44/44N	50/50N	53/53N	57/57N
Radius of Diffusion (ft.)	2-3-6	5-7-13	7-11-18	10-14-24	13-18-30	15-22-36	18-26-42	21-30-48
Air Flow (CFM)	628	1257	1885	2513	3142	3770	4398	5027
24" Total Pressure (w.g.)	0.01	0.05	0.12	0.20	0.28	0.40	0.54	0.71
Sound Level (NC/RC)	-- / --	28/28N	35/35N	40/40N	45/45N	50/51N	54/54N	58/58N
Radius of Diffusion (ft.)	3-4-8	5-8-15	9-13-22	12-17-29	15-22-36	18-26-44	22-30-51	25-36-58
Air Flow (CFM)	855	1710	2566	3421	4276	5131	5986	6842
28" Total Pressure (w.g.)	0.01	0.06	0.11	0.19	0.28	0.39	0.52	0.66
Sound Level (NC/RC)	-- / --	28/29N	35/35N	40/41N	45/46N	51/51N	54/54N	59/59N
Radius of Diffusion (ft.)	3-5-9	6-10-17	10-15-26	14-20-34	17-25-42	21-30-50	25-35-59	29-41-66
Air Flow (CFM)	1117	2234	3351	4468	5585	6702	7819	8936
32" Total Pressure (w.g.)	0.004	0.02	0.04	0.07	0.11	0.16	0.21	0.28
Sound Level (NC/RC)	-- / --	29/29N	36/36N	41/41N	46/46N	51/52N	55/56N	59/60N
Radius of Diffusion (ft.)	3-5-10	7-11-20	11-17-29	15-23-38	20-29-48	24-34-57	27-41-67	33-46-76
Air Flow (CFM)	1414	2827	4241	5655	7069	8482	9896	11310
36" Total Pressure (w.g.)	0.006	0.03	0.05	0.10	0.16	0.23	0.30	0.40
Sound Level (NC/RC)	-- / --	29/29N	36/37N	41/42N	46/47N	52/53N	56/57N	60/60N
Radius of Diffusion (ft.)	4-6-11	8-12-22	13-19-33	17-25-43	22-32-54	27-39-64	32-47-75	37-53-86

Notes on Performance Data:

- Performance data is based on tests conducted according to ANSI/ASHRAE Standard 70-1991.
- Actual performance in the field may vary.
- Testing was conducted in isothermal conditions.
- Sound levels are based on a room absorption of 10db re 10⁻¹² watts.
- A "--" indicates an NC or RC level less than 10.

Units of Measure Used:

- The duct velocity is given in Feet per Minute (FPM).
- Velocity Pressure and Total Pressure are given in Inches of Water (w.g.).
- Radius of Diffusion values are given in feet for terminal velocities of 150, 100 and 50 FPM, respectively.
- Sound data is given in both NC (Noise Criteria) and RC (Room Criteria). NC is first with RC second, separated by a slash.

Round Diffusers