

Imperial [IP] Dimensions  
Metric (SI) in Parentheses

CARNES COMPANY 448 S. Main St., P. O. Box 930040, Verona, WI 53593-0040 Phone: (608)845-6411 Fax: (608)845-6504 www.carnes.com

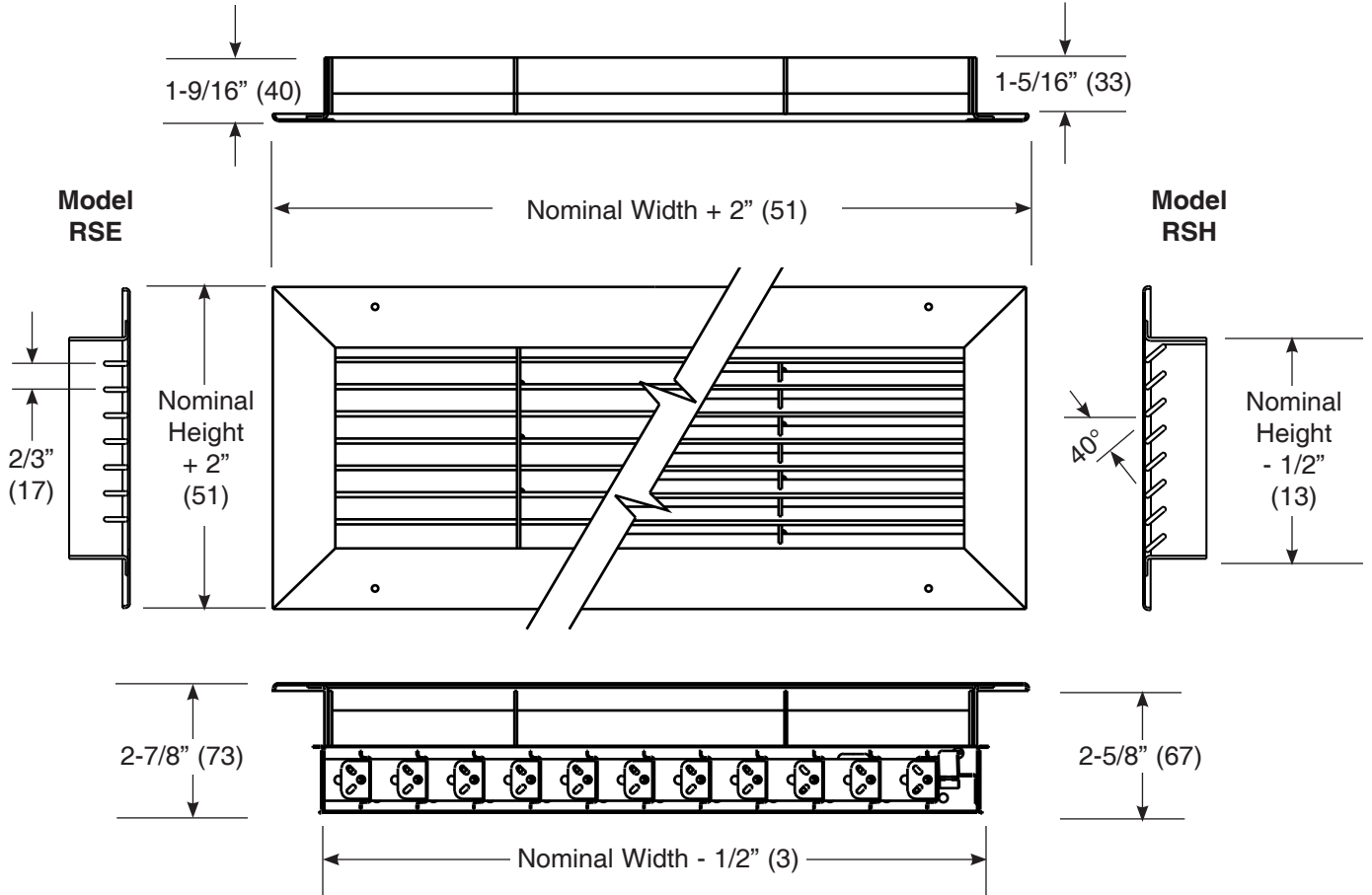

**Notes:**

1. Frame is made of 18 gauge formed steel.
2. Blades are made of 10 gauge rounded steel bars.
3. Blade spacing is 2/3" (17) on center.
4. Blade supports are made of 14 gauge steel.
5. Blade supports are on 6" (152) centers.
6. Minimum size available is 6" x 4" (152 x 102).
7. Maximum single panel size is 72" x 48" (1829 x 1219), assuming blades are parallel to the long dimension.
8. Sizes larger than 72" x 48" (1829 x 1219) can be furnished by joining single units together.
9. Standard color is #11 White. Other colors are available upon request.
10. Standard finish is electrocoat acrylic baked enamel. Other finishes are available upon request.
11. Recommended duct opening is Nominal Size.
12. Screws provided are #8 x 1-1/4" (32) countersunk Phillips head.
13. Screw holes are countersunk for flush appearance.

Model	Blade Setting	Blade Alignment	Damper	Available Sizes	
				Minimum WxH	Maximum WxH
RSHAH	40°	Horizontal	No	6" x 4" (152 x 102)	72" x 48" (1829 x 1219)
RSHAV	40°	Vertical	No	6" x 4" (152 x 102)	48" x 72" (1219 x 1829)
RSEAH	0°	Horizontal	No	6" x 4" (152 x 102)	72" x 48" (1829 x 1219)
RSEAV	0°	Vertical	No	6" x 4" (152 x 102)	48" x 72" (1219 x 1829)
RTHAH	40°	Horizontal	Yes	6" x 4" (152 x 102)	72" x 48" (1829 x 1219)
RTHAV	40°	Vertical	Yes	6" x 4" (152 x 102)	48" x 72" (1219 x 1829)
RTEAH	0°	Horizontal	Yes	6" x 4" (152 x 102)	72" x 48" (1829 x 1219)
RTEAV	0°	Vertical	Yes	6" x 4" (152 x 102)	48" x 72" (1219 x 1829)