

GRAVITY INTAKE AND EXHAUST ROOF VENTILATORS

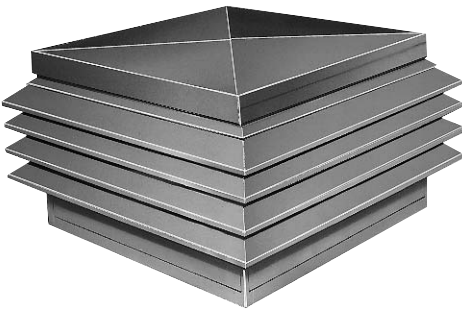

Series GE and GI Low Silhouette

This attractive low silhouette design is available in specific versions for intake and exhaust applications. The series GE models are normally used in exhaust applications. The GI series feature increased hood dimensions that allow lower inlet velocities that reduce moisture entrainment for intake applications. These units are available in either aluminum or galvanized steel.



Series GL Extruded Aluminum Louvered

The series GL, louvered penthouse, features a low profile that blends attractively with modern architectural design. These units are available in a wide variety of sizes and are suitable for either exhaust or intake applications. The GL is furnished completely assembled with fully welded mitered corners providing a simple-to-install and durable unit.



Series GS Spun Aluminum

The series GS series provides low silhouette design in attractive spun aluminum. These units are suitable for either intake or exhaust applications when properly selected. The GS features heavy-gauge, maintenance free aluminum construction that will provide years of attractive service.



Series VXC Spun Aluminum Roof Cap

This spun aluminum roof cap provides an economical intake or exhaust roof opening for small air flows. Available for curb cap mounting or flanged for direct roof mounting in round throat sizes from 8 to 20 inches. The single piece, spun aluminum cover is mounted on an aluminum throat with integral aluminum birdscreen.

Models GI - Gravity Intake Ventilator GE - Gravity Exhaust Ventilator

Model GI gravity intake ventilators are designed for supplying air via a “pull thru” method into the space or building.

The hood free area is double the throat free area, creating a 2:1 hood to throat ratio (Overall ratio is 3:1). The oversized hood makes this unit ideal for intake applications. These hoods should be sized with an approximate intake velocity of 600 fpm and with a corresponding throat velocity of 1200 fpm to help reduce moisture entrainment thru the hood.

These hoods are available in either galvanealed construction (Model GIGB) or aluminum construction (Model GIAB).

Model GE gravity exhaust ventilators are designed for exhausting air via “push thru” method from a space or building.

The hood free area and throat free area are equal, making this hood ideally suited for exhaust applications. If this hood is used for intake applications, it should be sized using an approximate intake/throat velocity of 600 fpm to help reduce moisture entrainment thru the hood.

These hoods are available in either galvanealed steel construction (Model GEGB) or aluminum construction (Model GEAB)

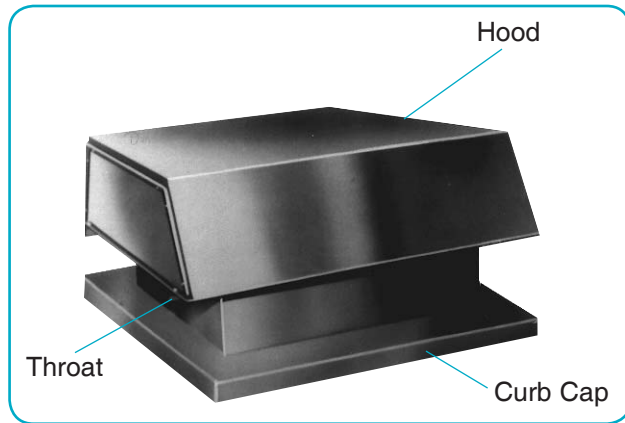

FEATURES

- Aluminum or steel construction.
- Integral galvanized birdscreen.
- Welded curb and throat seams.
- GI units feature enlarged hood.
- Gauges of construction vary with size of unit.

Structural Supports

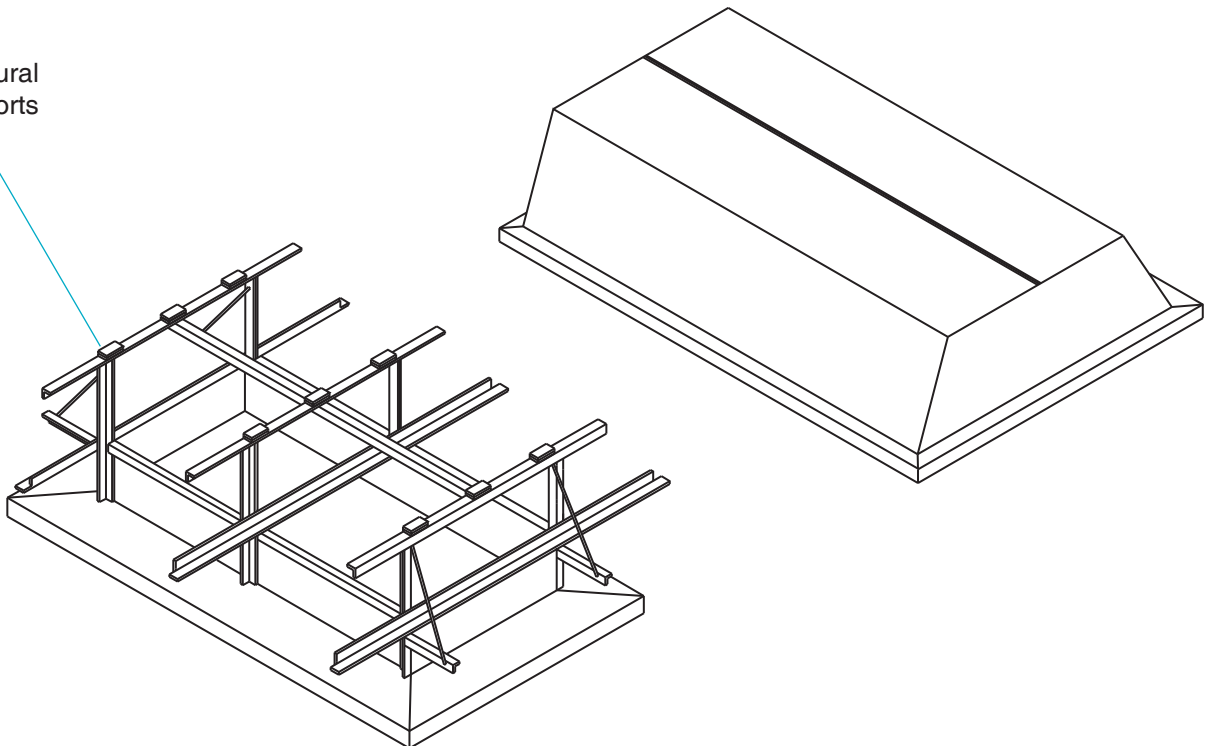

Model: GI

Dimensions (Inches)

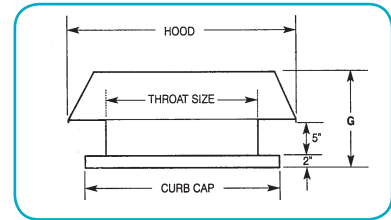

Performance Data (CFM)

Throat Size	Throat Area	Curb Cap	Hood A x B	G	INTAKE/THROAT VELOCITY (fpm)							
					400	500	600	700	800	900	1000	1200
12 x 12	1.00	20 x 20	21 x 21	10	400	500	600	700	800	900	1000	1200
12 x 18	1.50	20 x 26	22 x 28	10	600	750	900	1050	1200	1350	1500	1800
12 x 24	2.00	20 x 32	25 x 37	10	800	1000	1200	1400	1600	1800	2000	2400
12 x 30	2.50	20 x 38	25 x 43	10	1000	1250	1500	1750	2000	2250	2500	3000
12 x 36	3.00	20 x 44	25 x 51	10	1200	1500	1800	2100	2400	2700	3000	3600
12 x 42	3.50	20 x 50	27 x 57	10	1400	1750	2100	2450	2800	3150	3500	4200
12 x 48	4.00	20 x 56	27 x 63	10	1600	2000	2400	2800	3200	3600	4000	4800
14 x 14	1.36	22 x 22	25 x 25	11	544	681	817	953	1089	1225	1361	1633
14 x 18	1.75	22 x 26	26 x 30	11	700	875	1050	1225	1400	1575	1750	2100
14 x 24	2.33	22 x 32	27 x 37	11	933	1167	1400	1633	1867	2100	2333	2800
14 x 30	2.92	22 x 38	27 x 43	11	1167	1458	1750	2042	2333	2625	2917	3500
14 x 36	3.50	22 x 44	30 x 52	11	1400	1750	2100	2450	2800	3150	3500	4200
14 x 42	4.08	22 x 50	30 x 58	11	1633	2042	2450	2858	3267	3675	4083	4900
14 x 48	4.67	22 x 56	32 x 66	11	1867	2333	2800	3267	3733	4200	4667	5600
16 x 16	1.78	24 x 24	28 x 28	12	711	889	1067	1244	1422	1600	1778	2133
16 x 18	2.00	24 x 26	28 x 30	12	800	1000	1200	1400	1600	1800	2000	2400
16 x 24	2.67	24 x 32	31 x 39	12	1067	1333	1600	1867	2133	2400	2667	3200
16 x 30	3.33	24 x 38	31 x 45	12	1333	1667	2000	2333	2667	3000	3333	4000
16 x 36	4.00	24 x 44	34 x 54	12	1600	2000	2400	2800	3200	3600	4000	4800
16 x 42	4.67	24 x 50	34 x 60	12	1867	2333	2800	3267	3733	4200	4667	5600
16 x 48	5.33	24 x 56	35 x 67	12	2133	2667	3200	3733	4267	4800	5333	6400
16 x 54	6.00	24 x 62	35 x 73	12	2400	3000	3600	4200	4800	5400	6000	7200
18 x 18	2.25	26 x 26	32 x 32	12	900	1125	1350	1575	1800	2025	2250	2700
18 x 20	2.50	26 x 28	32 x 34	12	1000	1250	1500	1750	2000	2250	2500	3000
18 x 24	3.00	26 x 32	33 x 39	12	1200	1500	1800	2100	2400	2700	3000	3600
18 x 30	3.75	26 x 38	36 x 48	12	1500	1875	2250	2625	3000	3375	3750	4500
18 x 36	4.50	26 x 44	36 x 54	12	1800	2250	2700	3150	3600	4050	4500	5400
18 x 42	5.25	26 x 50	38 x 62	12	2100	2625	3150	3675	4200	4725	5250	6300
18 x 48	6.00	26 x 56	38 x 68	12	2400	3000	3600	4200	4800	5400	6000	7200
18 x 54	6.75	26 x 62	40 x 76	12	2700	3375	4050	4725	5400	6075	6750	8100
18 x 60	7.50	26 x 68	40 x 82	12	3000	3750	4500	5250	6000	6750	7500	9000
20 x 20	2.78	28 x 28	35 x 35	13	1111	1389	1667	1944	2222	2500	2778	3333
20 x 22	3.06	28 x 30	35 x 37	13	1222	1528	1833	2139	2444	2750	3056	3667
20 x 24	3.33	28 x 32	37 x 41	13	1333	1667	2000	2333	2667	3000	3333	4000
20 x 30	4.17	28 x 38	37 x 47	13	1667	2083	2500	2917	3333	3750	4167	5000
20 x 36	5.00	28 x 44	40 x 56	13	2000	2500	3000	3500	4000	4500	5000	6000
20 x 42	5.83	28 x 50	40 x 62	13	2333	2917	3500	4083	4667	5250	5833	7000
20 x 48	6.67	28 x 56	42 x 70	13	2667	3333	4000	4667	5333	6000	6667	8000
20 x 54	7.50	28 x 62	42 x 76	13	3000	3750	4500	5250	6000	6750	7500	9000
20 x 60	8.33	28 x 68	44 x 84	13	3333	4167	5000	5833	6667	7500	8333	10000
20 x 66	9.17	28 x 74	44 x 90	13	3667	4583	5500	6417	7333	8250	9167	11000
20 x 72	10.00	28 x 80	46 x 98	13	4000	5000	6000	7000	8000	9000	10000	12000
20 x 84	11.67	28 x 92	46 x 110	13	4667	5833	7000	8167	9333	10500	11667	14000
22 x 22	3.36	30 x 30	39 x 39	14	1344	1681	2017	2353	2689	3025	3361	4033
22 x 24	3.67	30 x 32	39 x 41	14	1467	1833	2200	2567	2933	3300	3667	4400
22 x 30	4.58	30 x 38	43 x 51	14	1833	2292	2750	3208	3667	4125	4583	5500
22 x 36	5.50	30 x 44	43 x 57	14	2200	2750	3300	3850	4400	4950	5500	6600
22 x 42	6.43	30 x 50	43 x 63	14	2567	3208	3850	4492	5133	5775	6417	7700
22 x 48	7.33	30 x 56	46 x 72	14	2933	3667	4400	5133	5867	6600	7333	8800
22 x 54	8.25	30 x 62	46 x 78	14	3300	4125	4950	5775	6600	7425	8250	9900
22 x 60	9.17	30 x 68	48 x 86	14	3667	4583	5500	6417	7333	8250	9167	11000
22 x 66	10.08	30 x 74	48 x 92	14	4033	5042	6050	7058	8067	9075	10083	12100
22 x 72	11.00	30 x 80	48 x 98	14	4400	5500	6600	7700	8800	9900	11000	13200
22 x 84	12.83	30 x 92	49 x 111	14	5133	6417	7700	8983	10267	11550	12833	15400
24 x 24	4.00	32 x 32	44 x 44	15	1600	2000	2400	2800	3200	3600	4000	4800
24 x 30	5.00	32 x 38	44 x 50	15	2000	2500	3000	3500	4000	4500	5000	6000
24 x 36	6.00	32 x 44	46 x 58	15	2400	3000	3600	4200	4800	5400	6000	7200
24 x 42	7.00	32 x 50	46 x 64	15	2800	3500	4200	4900	5600	6300	7000	8400
24 x 48	8.00	32 x 56	49 x 73	15	3200	4000	4800	5600	6400	7200	8000	9600
24 x 54	9.00	32 x 62	49 x 79	15	3600	4500	5400	6300	7200	8100	9000	10800
24 x 60	10.00	32 x 68	51 x 87	15	4000	5000	6000	7000	8000	9000	10000	12000
24 x 66	11.00	32 x 74	51 x 93	15	4400	5500	6600	7700	8800	9900	11000	13200
24 x 72	12.00	32 x 80	52 x 100	15	4800	6000	7200	8400	9600	10800	12000	14400
24 x 84	14.00	32 x 92	52 x 113	15	5600	7000	8400	9800	11200	12600	14000	16800
24 x 96	16.00	32 x 104	54 x 126	15	6400	8000	9600	11200	12800	14400	16000	19200

Gravity Ventilators

Model: **GI** *(Continued)*

Dimensions (Inches)

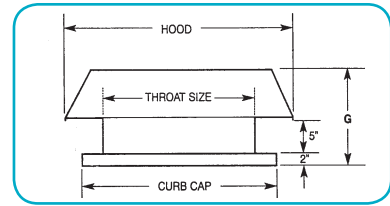

Performance Data (CFM)

Throat Size	Throat Area	Curb Cap	Hood A x B	G	INTAKE/THROAT VELOCITY (fpm)							
					400	500	600	700	800	900	1000	1200
30 x 30	6.25	38 x 38	52 x 52	17	2500	3125	3750	4375	5000	5625	6250	7500
30 x 36	7.50	38 x 44	54 x 60	17	3000	3750	4500	5250	6000	6750	7500	9000
30 x 42	8.75	38 x 50	57 x 69	17	3500	4375	5250	6125	7000	7875	8750	10500
30 x 48	10.00	38 x 56	57 x 75	17	4000	5000	6000	7000	8000	9000	10000	12000
30 x 54	11.25	38 x 62	60 x 84	17	4500	5625	6750	7875	9000	10125	11250	13500
30 x 60	12.50	38 x 68	60 x 90	17	5000	6250	7500	8750	10000	11250	12500	15000
30 x 66	13.75	38 x 74	62 x 98	17	5500	6875	8250	9625	11000	12375	13750	16500
30 x 72	15.00	38 x 80	62 x 104	17	6000	7500	9000	10500	12000	13500	15000	18000
30 x 84	17.50	38 x 92	63 x 117	17	7000	8750	10500	12250	14000	15750	17500	21000
30 x 96	20.00	38 x 104	65 x 131	17	8000	10000	12000	14000	16000	18000	20000	24000
30 x 108	22.50	38 x 116	67 x 145	17	9000	11250	13500	15750	18000	20250	22500	27000
30 x 120	25.00	38 x 128	68 x 158	17	10000	12500	15000	17500	20000	22500	25000	30000
36 x 36	9.00	44 x 44	62 x 62	20	3600	4500	5400	6300	7200	8100	9000	10800
36 x 42	10.50	44 x 50	65 x 71	20	4200	5250	6300	7350	8400	9450	10500	12600
36 x 48	12.00	44 x 56	65 x 77	20	4800	6000	7200	8400	9600	10800	12000	14400
36 x 54	13.50	44 x 62	69 x 87	20	5400	6750	8100	9450	10800	12150	13500	16200
36 x 60	15.00	44 x 68	69 x 93	20	6000	7500	9000	10500	12000	13500	15000	18000
36 x 66	16.50	44 x 74	70 x 100	20	6600	8250	9900	11550	13200	14850	16500	19800
36 x 72	18.00	44 x 80	71 x 107	20	7200	9000	10800	12600	14400	16200	18000	21600
36 x 84	21.00	44 x 92	74 x 122	20	8400	10500	12600	14700	16800	18900	21000	25200
36 x 96	24.00	44 x 104	76 x 136	20	9600	12000	14400	16800	19200	21600	24000	28800
36 x 108	27.00	44 x 116	78 x 150	20	10800	13500	16200	18900	21600	24300	27000	32400
36 x 120	30.00	44 x 128	79 x 163	20	12000	15000	18000	21000	24000	27000	30000	36000
42 x 42	12.25	50 x 50	74 x 74	22	4900	6125	7350	8575	9800	11025	12250	14700
42 x 48	14.00	50 x 56	74 x 80	22	5600	7000	8400	9800	11200	12600	14000	16800
42 x 54	15.75	50 x 62	78 x 90	22	6300	7875	9450	11025	12600	14175	15750	18900
42 x 60	17.50	50 x 68	78 x 96	22	7000	8750	10500	12250	14000	15750	17500	21000
42 x 66	19.25	50 x 74	80 x 104	22	7700	9625	11550	13475	15400	17325	19250	23100
42 x 72	21.00	50 x 80	81 x 111	22	8400	10500	12600	14700	16800	18900	21000	25200
42 x 84	24.5	50 x 92	83 x 125	22	9800	12250	14700	17150	19600	22050	24500	29400
42 x 96	28.00	50 x 104	86 x 140	22	11200	14000	16800	19600	22400	25200	28000	33600
42 x 108	31.50	50 x 116	88 x 154	22	12600	15750	18900	22050	25200	28350	31500	37800
42 x 120	35.00	50 x 128	90 x 168	22	14000	17500	21000	24500	28000	31500	35000	42000
48 x 48	16.00	56 x 56	84 x 84	25	6400	8000	9600	11200	12800	14400	16000	19200
48 x 54	18.00	56 x 62	84 x 90	25	7200	9000	10800	12600	14400	16200	18000	21600
48 x 60	20.00	56 x 68	87 x 99	25	8000	10000	12000	14000	16000	18000	20000	24000
48 x 66	22.00	56 x 74	88 x 108	25	8800	11000	13200	15400	17600	19800	22000	26400
48 x 72	24.00	56 x 80	90 x 114	25	9600	12000	14400	16800	19200	21600	24000	28800
48 x 84	18.00	56 x 92	93 x 129	25	11200	14000	16800	19600	22400	25200	28000	33600
48 x 96	32.00	56 x 104	96 x 144	25	12800	16000	19200	21400	25600	28800	32000	38400
48 x 108	36.00	56 x 116	98 x 158	25	14400	18000	21600	25200	28800	32400	36000	43200
48 x 120	40.00	56 x 128	100 x 172	25	16000	20000	24000	28000	32000	36000	40000	48000
54 x 54	20.25	62 x 62	94 x 94	27	8100	10125	12150	14175	16200	18225	20250	24300
54 x 60	22.50	62 x 68	96 x 102	27	9000	11250	13500	15750	18000	20250	22500	27000
54 x 66	24.75	62 x 74	98 x 110	27	9900	12375	14850	17325	19800	22275	24750	29700
54 x 72	27.00	62 x 80	99 x 117	27	10800	13500	16200	18900	21600	24300	27000	32400
54 x 84	31.50	62 x 92	103 x 133	27	12600	15750	18900	22050	25200	28350	31500	37800
54 x 96	36.00	62 x 104	105 x 147	27	14400	18000	21600	25200	28800	32400	36000	43200
54 x 108	40.50	62 x 116	108 x 162	27	16200	20250	24300	28350	32400	36450	40500	48600
54 x 120	45.00	62 x 128	110 x 175	27	18000	22500	27000	31500	36000	40500	45000	54000
60 x 60	25.00	68 x 68	104 x 104	29	10000	12500	15000	17500	20000	22500	25000	30000
60 x 66	27.50	68 x 74	106 x 112	29	11000	13750	16500	19250	22000	24750	27500	33000
60 x 72	30.00	68 x 80	108 x 120	29	12000	15000	18000	21000	24000	27000	30000	36000
60 x 84	35.00	68 x 92	112 x 136	29	14000	17500	21000	24500	28000	31500	35000	42000
60 x 90	40.00	68 x 104	115 x 151	29	16000	20000	24000	28000	32000	36000	40000	48000
60 x 108	45.00	68 x 116	117 x 165	29	18000	22500	27000	31500	36000	40500	45000	54000
60 x 120	50.00	68 x 128	120 x 180	29	20000	25000	30000	35000	40000	45000	50000	60000
66 x 66	30.25	74 x 74	114 x 114	32	12100	15125	18150	21175	24200	27225	30250	36300
66 x 72	33.00	74 x 80	116 x 122	32	13200	16500	19800	23100	26400	29700	33000	39600
66 x 84	38.50	74 x 92	120 x 138	32	15400	19250	23100	26950	30800	34650	38500	46200
66 x 96	44.00	74 x 104	124 x 154	32	17600	22000	26400	30800	35200	39600	44000	52800
66 x 108	49.50	74 x 116	127 x 169	32	19800	24750	29700	34650	39600	44550	49500	59400
66 x 120	55.00	74 x 128	129 x 183	32	22000	27500	33000	38500	44000	49500	55000	66000
72 x 72	36.00	80 x 80	125 x 125	34	14400	18000	21600	25200	28800	32400	36000	43200
72 x 84	42.00	80 x 92	129 x 141	34	16800	21000	25200	29400	33600	37800	42000	50400
72 x 96	48.00	80 x 104	129 x 153	34	19200	24000	28800	33600	38400	43200	48000	57600
72 x 108	54.00	80 x 116	135 x 171	34	21600	27000	32400	37800	43200	48600	54000	64800
72 x 120	60.00	80 x 128	135 x 183	34	24000	30000	36000	42000	48000	54000	60000	72000

Gravity Ventilators

Model: GE

Dimensions (Inches)

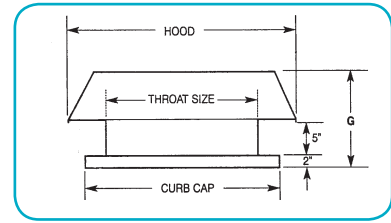

Performance Data (CFM)

Throat Size	Throat Area	Curb Cap	Hood A x B	G	INTAKE/THROAT VELOCITY (fpm)							
					400	500	600	700	800	900	1000	1200
12 x 12	1.00	20 x 20	17 x 17	9	400	500	600	700	800	900	1000	1200
12 x 18	1.50	20 x 26	18 x 24	9	600	750	900	1050	1200	1350	1500	1800
12 x 24	2.00	20 x 32	19 x 31	9	800	1000	1200	1400	1600	1800	2000	2400
12 x 30	2.50	20 x 38	19 x 37	9	1000	1250	1500	1750	2000	2250	2500	3000
12 x 36	3.00	20 x 44	20 x 44	9	1200	1500	1800	2100	2400	2700	3000	3600
12 x 42	3.50	20 x 50	20 x 50	9	1400	1750	2100	2450	2800	3150	3500	4200
12 x 48	4.00	20 x 56	20 x 56	9	1600	2000	2400	2800	3200	3600	4000	4800
14 x 14	1.36	22 x 22	20 x 20	9	544	681	817	953	1089	1225	1361	1633
14 x 18	1.75	22 x 26	21 x 25	9	700	875	1050	1225	1400	1575	1750	2100
14 x 24	2.33	22 x 32	21 x 31	9	933	1167	1400	1633	1867	2100	2333	2800
14 x 30	2.92	22 x 38	23 x 39	9	1167	1458	1750	2042	2333	2625	2917	3500
14 x 36	3.50	22 x 44	23 x 45	9	1400	1750	2100	2450	2800	3150	3500	4200
14 x 42	4.08	22 x 50	23 x 51	9	1633	2042	2450	2858	3267	3675	4083	4900
14 x 48	4.67	22 x 56	23 x 57	9	1867	2333	2800	3267	3733	4200	4667	5600
16 x 16	1.78	24 x 24	23 x 23	10	711	889	1067	1244	1422	1600	1778	2133
16 x 18	2.00	24 x 26	23 x 25	10	800	1000	1200	1400	1600	1800	2000	2400
16 x 24	2.67	24 x 32	24 x 32	10	1067	1333	1600	1867	2133	2400	2667	3200
16 x 30	3.33	24 x 38	25 x 39	10	1333	1667	2000	2333	2667	3000	3333	4000
16 x 36	4.00	24 x 44	25 x 45	10	1600	2000	2400	2800	3200	3600	4000	4800
16 x 42	4.67	24 x 50	26 x 52	10	1867	2333	2800	3267	3733	4200	4667	5600
16 x 48	5.33	24 x 56	26 x 58	10	2133	2667	3200	3733	4267	4800	5333	6400
16 x 54	6.00	24 x 62	27 x 65	10	2400	3000	3600	4200	4800	5400	6000	7200
18 x 18	2.25	26 x 26	26 x 26	11	900	1125	1350	1575	1800	2025	2250	2700
18 x 20	2.50	24 x 28	26 x 28	11	1000	1250	1500	1750	2000	2250	2500	3000
18 x 24	3.00	24 x 32	27 x 33	11	1200	1500	1800	2100	2400	2700	3000	3600
18 x 30	3.75	24 x 38	27 x 39	11	1500	1875	2250	2625	3000	3375	3750	4500
18 x 36	4.50	24 x 44	29 x 47	11	1800	2250	2700	3150	3600	4050	4500	5400
18 x 42	5.25	24 x 50	29 x 53	11	2100	2625	3150	3675	4200	4725	5250	6300
18 x 48	6.00	24 x 56	29 x 59	11	2400	3000	3600	4200	4800	5400	6000	7200
18 x 54	6.75	24 x 62	30 x 66	11	2700	3375	4050	4725	5400	6075	6750	8100
18 x 60	7.50	24 x 68	30 x 72	11	3000	3750	4500	5250	6000	6750	7500	9000
20 x 20	2.78	28 x 28	29 x 29	12	1111	1389	1667	1944	2222	2500	2778	3333
20 x 22	3.06	28 x 30	29 x 31	12	1222	1528	1833	2139	2444	2750	3056	3667
20 x 24	3.33	28 x 32	29 x 33	12	1333	1667	2000	2333	2667	3000	3333	4000
20 x 30	4.17	28 x 38	31 x 41	12	1667	2083	2500	2917	3333	3750	4167	5000
20 x 36	5.00	28 x 44	31 x 47	12	2000	2500	3000	3500	4000	4500	5000	6000
20 x 42	5.83	28 x 50	31 x 53	12	2333	2917	3500	4083	4667	5250	5833	7000
20 x 48	6.67	28 x 56	32 x 60	12	2667	3333	4000	4667	5333	6000	6667	8000
20 x 54	7.50	28 x 62	32 x 66	12	3000	3750	4500	5250	6000	6750	7500	9000
20 x 60	8.33	28 x 68	33 x 73	12	3333	4167	5000	5833	6667	7500	8333	10000
20 x 66	9.17	28 x 74	33 x 79	12	3667	4583	5500	6417	7333	8250	9167	11000
20 x 72	10.00	28 x 80	34 x 86	12	4000	5000	6000	7000	8000	9000	10000	12000
20 x 84	11.67	28 x 92	34 x 98	12	4667	5833	7000	8167	9333	10500	11667	14000
22 x 22	3.36	30 x 30	32 x 32	12	1344	1681	2017	2353	2689	3025	3361	4033
22 x 24	3.67	30 x 32	32 x 34	12	1467	1833	2200	2567	2933	3300	3667	4400
22 x 30	4.58	30 x 38	33 x 41	12	1833	2292	2750	3208	3667	4125	4583	5500
22 x 36	5.50	30 x 44	33 x 47	12	2200	2750	3300	3850	4400	4950	5500	6600
22 x 42	6.43	30 x 50	35 x 55	12	2567	3208	3850	4492	5133	5775	6417	7700
22 x 48	7.33	30 x 56	35 x 61	12	2933	3667	4400	5133	5867	6600	7333	8800
22 x 54	8.25	30 x 62	25 x 67	12	3300	4125	4950	5775	6600	7425	8250	9900
22 x 60	9.17	30 x 68	36 x 74	12	3667	4583	5500	6417	7333	8250	9167	11000
22 x 66	10.08	30 x 74	36 x 80	12	4033	5042	6050	7058	8067	9075	10083	12100
22 x 72	11.00	30 x 80	37 x 87	12	4400	5500	6600	7700	8800	9900	11000	13200
22 x 84	12.83	30 x 92	37 x 99	12	5133	6417	7700	8983	10267	11550	12833	15400
24 x 24	4.00	32 x 32	35 x 35	13	1600	2000	2400	2800	3200	3600	4000	4800
24 x 30	5.00	32 x 38	35 x 41	13	2000	2500	3000	3500	4000	4500	5000	6000
24 x 36	6.00	32 x 44	37 x 40	13	2400	3000	3600	4200	4800	5400	6000	7200
24 x 42	7.00	32 x 50	37 x 55	13	2800	3500	4200	4900	5600	6300	7000	8400
24 x 48	8.00	32 x 56	37 x 61	13	3200	4000	4800	5600	6400	7200	8000	9600
24 x 54	9.00	32 x 62	39 x 69	13	3600	4500	5400	6300	7200	8100	9000	10800
24 x 60	10.00	32 x 68	39 x 75	13	4000	5000	6000	7000	8000	9000	10000	12000
24 x 66	11.00	32 x 74	39 x 81	13	4400	5500	6600	7700	8800	9900	11000	13200
24 x 72	12.00	32 x 80	39 x 87	13	4800	6000	7200	8400	9600	10800	12000	14400
24 x 84	14.00	32 x 92	40 x 100	13	5600	7000	8400	9800	11200	12600	14000	16800
24 x 96	16.00	32 x 104	41 x 113	13	6400	8000	9600	11200	12800	14400	16000	19200

Gravity Ventilators

Model: GE (Continued)

Dimensions (Inches)

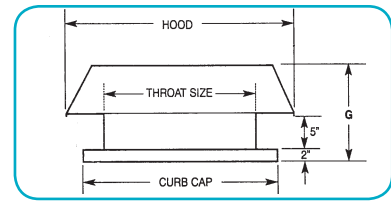

Performance Data (CFM)

Throat Size	Throat Area	Curb Cap	Hood A x B	G	INTAKE/THROAT VELOCITY (fpm)							
					400	500	600	700	800	900	1000	1200
30 x 30	6.25	38 x 38	42 x 42	15	2500	3125	3750	4375	5000	5625	6250	7500
30 x 36	7.50	38 x 44	45 x 51	15	3000	3750	4500	5250	6000	6750	7500	9000
30 x 42	8.75	38 x 50	45 x 57	15	3500	4375	5250	6125	7000	7875	8750	10500
30 x 48	10.00	38 x 56	45 x 63	15	4000	5000	6000	7000	8000	9000	10000	12000
30 x 54	11.25	38 x 62	47 x 71	15	4500	5625	6750	7875	9000	10125	11250	13500
30 x 60	12.50	38 x 68	47 x 77	15	5000	6250	7500	8750	10000	11250	12500	15000
30 x 66	13.75	38 x 74	47 x 83	15	5500	6875	8250	9625	11000	12375	13750	16500
30 x 72	15.00	38 x 80	49 x 91	15	6000	7500	9000	10500	12000	13500	15000	18000
30 x 84	17.50	38 x 92	49 x 103	15	7000	8750	10500	12250	14000	15750	17500	21000
30 x 96	20.00	38 x 104	50 x 116	15	8000	10000	12000	14000	16000	18000	20000	24000
30 x 108	22.50	38 x 116	50 x 128	15	9000	11250	13500	15750	18000	20250	22500	27000
30 x 120	25.00	38 x 128	51 x 141	15	10000	12500	15000	17500	20000	22500	25000	30000
36 x 36	9.00	44 x 44	52 x 52	17	3600	4500	5400	6300	7200	8100	9000	10800
36 x 42	10.50	44 x 50	52 x 58	17	4200	5250	6300	7350	8400	9450	10500	12600
36 x 48	12.00	44 x 56	54 x 66	17	4800	6000	7200	8400	9600	10800	12000	14400
36 x 54	13.50	44 x 62	54 x 72	17	5400	6750	8100	9450	10800	12150	13500	16200
36 x 60	15.00	44 x 68	56 x 80	17	6000	7500	9000	10500	12000	13500	15000	18000
36 x 66	16.50	44 x 74	56 x 96	17	6600	8250	9900	11550	13200	14850	16500	19800
36 x 72	18.00	44 x 80	56 x 92	17	7200	9000	10800	12600	14400	16200	18000	21600
36 x 84	21.00	44 x 92	57 x 105	17	8400	10500	12600	14700	16800	18900	21000	25200
36 x 96	24.00	44 x 104	58 x 118	17	9600	12000	14400	16800	19200	21600	24000	28800
36 x 108	27.00	44 x 116	59 x 131	17	10800	13500	16200	18900	21600	24300	27000	32400
36 x 120	30.00	44 x 128	60 x 144	17	12000	15000	18000	21000	24000	27000	30000	36000
42 x 42	12.25	50 x 50	58 x 58	19	4900	6125	7350	8575	9800	11025	12250	14700
42 x 48	14.00	50 x 56	61 x 67	19	5600	7000	8400	9800	11200	12600	14000	16800
42 x 54	15.75	50 x 62	61 x 73	19	6300	7875	9450	11025	12600	14175	15750	18900
42 x 60	17.50	50 x 68	63 x 87	19	7000	8750	10500	12250	14000	15750	17500	21000
42 x 66	19.25	50 x 74	63 x 87	19	7700	9625	11550	13475	15400	17325	19250	23100
42 x 72	21.00	50 x 80	63 x 93	19	8400	10500	12600	14700	16800	18900	21000	25200
42 x 84	24.50	50 x 92	65 x 107	19	9800	12250	14700	17150	19600	22050	24500	29400
42 x 96	28.00	50 x 104	66 x 120	19	11200	14000	16800	19600	22400	25200	28000	33600
42 x 108	31.50	50 x 116	67 x 133	19	12600	15750	18900	22050	25200	28350	31500	37800
42 x 120	35.00	50 x 128	68 x 148	19	14000	17500	21000	24500	28000	31500	35000	42000
48 x 48	16.00	56 x 56	69 x 69	21	6400	8000	9600	11200	12800	14400	16000	19200
48 x 54	18.00	56 x 62	69 x 75	21	7200	9000	10800	12600	14400	16200	18000	21600
48 x 60	20.00	56 x 68	71 x 83	21	8000	10000	12000	14000	16000	18000	20000	24000
48 x 66	22.00	56 x 74	71 x 89	21	8800	11000	13200	15400	17600	19800	22000	26400
48 x 72	24.00	56 x 80	71 x 95	21	9600	12000	14400	16800	19200	21600	24000	28800
48 x 84	18.00	56 x 92	73 x 109	21	11200	14000	16800	19600	22400	25200	28000	33600
48 x 96	32.00	56 x 104	75 x 123	21	12800	16000	19200	22400	25600	28800	32000	38400
48 x 108	36.00	56 x 116	76 x 136	21	14400	18000	21600	25200	28800	32400	36000	43200
48 x 120	40.00	56 x 128	77 x 149	21	16000	20000	24000	28000	32000	36000	40000	48000
54 x 54	20.25	62 x 62	76 x 76	23	8100	10125	12150	14175	16200	18225	20250	24300
54 x 60	22.50	62 x 68	79 x 85	23	9000	11250	13500	15750	18000	20250	22500	27000
54 x 66	24.75	62 x 74	79 x 91	23	9900	12375	14850	17325	19800	22275	24750	29700
54 x 72	27.00	62 x 80	80 x 98	23	10800	13500	16200	18900	21600	24300	27000	32400
54 x 84	31.50	62 x 92	81 x 111	23	12600	15750	18900	22050	25200	28350	31500	37800
54 x 96	36.00	62 x 104	83 x 125	23	14400	18000	21600	25200	28800	32400	36000	43200
54 x 108	40.50	62 x 116	84 x 138	23	16200	20250	24300	28350	32400	36450	40500	48600
54 x 120	45.00	62 x 128	85 x 151	23	18000	22500	27000	31500	36000	40500	45000	54000
60 x 60	25.00	68 x 68	86 x 86	25	10000	12500	15000	17500	20000	22500	25000	30000
60 x 66	27.50	68 x 74	86 x 92	25	11000	13750	16500	19250	22000	24750	27500	33000
60 x 72	30.00	68 x 80	87 x 99	25	12000	15000	18000	21000	24000	27000	30000	36000
60 x 84	35.00	68 x 92	89 x 113	25	14000	17500	21000	24500	28000	31500	35000	42000
60 x 90	40.00	68 x 104	90 x 126	25	16000	20000	24000	28000	32000	36000	40000	48000
60 x 108	45.00	68 x 116	92 x 140	25	18000	22500	27000	31500	36000	40500	45000	54000
60 x 120	50.00	68 x 128	93 x 153	25	20000	25000	30000	35000	40000	45000	50000	60000
66 x 66	30.25	74 x 74	93 x 93	26	12100	15125	18150	21175	24200	27225	30250	36300
66 x 72	33.00	74 x 80	95 x 101	26	13200	16500	19800	23100	26400	29700	33000	39600
66 x 84	38.50	74 x 92	97 x 115	26	15400	19250	23100	26950	30800	34650	38500	46200
66 x 96	44.00	74 x 104	98 x 128	26	17600	22000	26400	30800	35200	39600	44000	52800
66 x 108	49.50	74 x 116	100 x 142	26	19800	24750	29700	34650	39600	44550	49500	59400
66 x 120	55.00	74 x 128	101 x 155	26	22000	27500	33000	38500	44000	49500	55000	66000
72 x 72	36.00	80 x 80	102 x 102	28	14400	18000	21600	25200	28800	32400	36000	43200
72 x 84	42.00	80 x 92	104 x 116	28	16800	21000	25200	29400	33600	37800	42000	50400
72 x 96	48.00	80 x 104	106 x 130	28	19200	24000	28800	33600	38400	43200	48000	57600
72 x 108	54.00	80 x 116	108 x 144	28	21600	27000	32400	37800	43200	48600	54000	64800
72 x 120	60.00	80 x 128	110 x 158	28	24000	30000	36000	42000	48000	54000	60000	72000

Gravity Ventilators

Model GLAB - Extruded Aluminum Louvered Intake or Exhaust Ventilator

The Model GLAB gravity hoods feature an extruded aluminum louvered construction with fully welded mitered corners and integral birdscreen.

These hoods are designed for either intake or exhaust and feature 1:1 intake/throat ratio. When used for intake applications, it should be sized using an approximate intake/throat velocity of 600 fpm to help prevent moisture entrainment through the louvers.

FEATURES

- Extruded aluminum construction.
- Fully welded mitered corners.
- Integral birdscreen.
- Integral curb base.

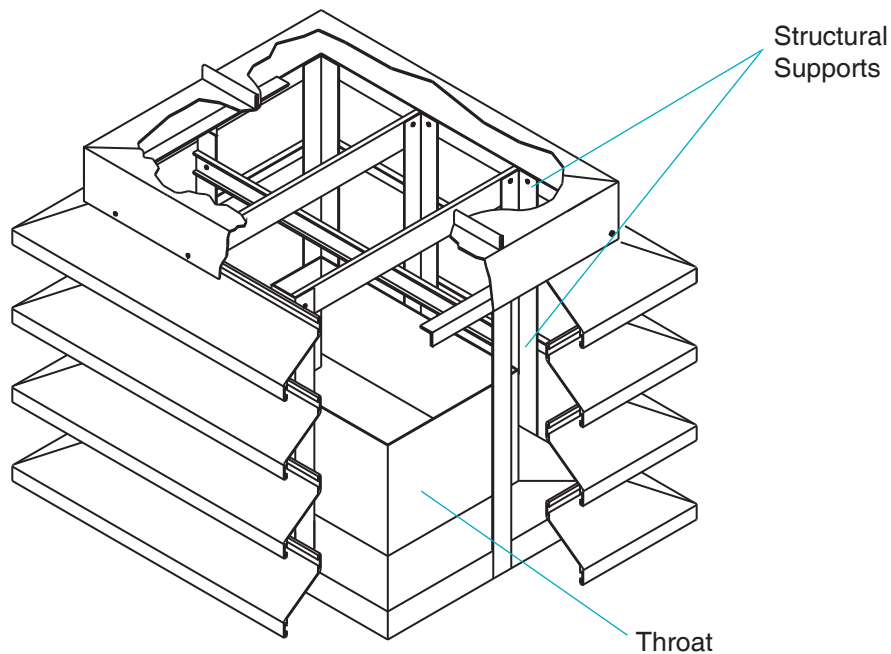
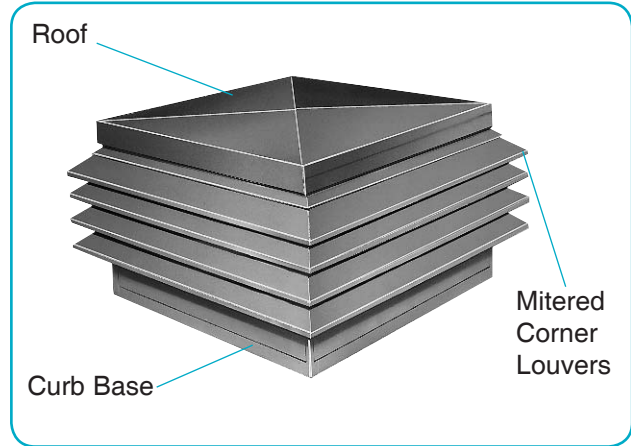

Model: GL

Dimensions (Inches)

Performance Data (CFM)

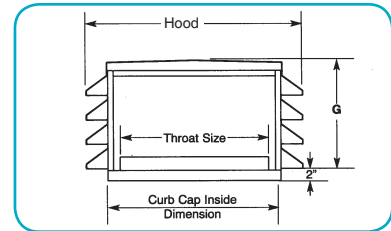

Throat Size	Throat Area	Curb Cap	Hood A x B	G	INTAKE/THROAT VELOCITY (fpm)							
					400	500	600	700	800	900	1000	1200
12 x 12	1.00	20 x 20	28 x 28	9.5	400	500	600	700	800	900	1000	1200
12 x 14	1.17	20 x 22	28 x 30	9.5	467	583	700	817	933	1050	1167	1400
12 x 16	1.33	20 x 24	28 x 32	9.5	533	667	800	933	1067	1200	1333	1600
12 x 18	1.50	20 x 26	28 x 34	9.5	600	750	900	1050	1200	1350	1500	1800
12 x 20	1.67	20 x 28	28 x 36	9.5	667	833	1000	1167	1333	1500	1667	2000
12 x 22	1.83	20 x 30	28 x 38	9.5	733	917	1100	1283	1467	1650	1833	2200
12 x 24	2.00	20 x 32	28 x 40	9.5	800	1000	1200	1400	1600	1800	2000	2400
12 x 30	2.50	20 x 38	28 x 46	9.5	1000	1250	1500	1750	2000	2250	2500	3000
12 x 36	3.00	20 x 44	28 x 52	9.5	1200	1500	1800	2100	2400	2700	3000	3600
12 x 42	3.50	20 x 50	28 x 58	9.5	1400	1750	2100	2450	2800	3150	3500	4200
12 x 48	4.00	20 x 56	28 x 64	9.5	1600	2000	2400	2800	3200	3600	4000	4800
12 x 54	4.50	20 x 62	28 x 70	9.5	1800	2250	2700	3150	3600	4050	4500	5400
14 x 14	1.36	22 x 22	30 x 30	9.5	544	681	817	953	1089	1225	1361	1633
14 x 16	1.56	22 x 24	30 x 32	9.5	622	778	933	1089	1244	1400	1556	1867
14 x 18	1.75	22 x 26	30 x 34	9.5	700	875	1050	1225	1400	1575	1750	2100
14 x 20	1.94	22 x 28	30 x 36	9.5	778	972	1167	1361	1556	1750	1944	2333
14 x 22	2.14	22 x 30	30 x 38	9.5	856	1069	1283	1497	1711	1925	2139	2567
14 x 24	2.33	22 x 32	30 x 40	9.5	933	1167	1400	1633	1867	2100	2333	2800
14 x 30	2.92	22 x 38	30 x 46	9.5	1167	1458	1750	2042	2333	2625	2917	3500
14 x 36	3.50	22 x 44	30 x 52	9.5	1400	1750	2100	2450	2800	3150	3500	4200
14 x 42	4.08	22 x 50	30 x 58	9.5	1633	2042	2450	2858	3267	3675	4083	4900
14 x 48	4.67	22 x 56	30 x 64	9.5	1867	2333	2800	3267	3733	4200	4667	5600
14 x 54	5.25	22 x 62	30 x 70	14	2100	2625	3150	3675	4200	4725	5250	6300
14 x 60	5.83	22 x 68	30 x 76	14	2333	2917	3500	4083	4667	5250	5833	7000
16 x 16	1.78	24 x 24	32 x 32	9.5	711	889	1067	1244	1422	1600	1778	2133
16 x 18	2.00	24 x 26	32 x 34	9.5	800	1000	1200	1400	1600	1800	2000	2400
16 x 20	2.22	24 x 28	32 x 36	9.5	889	1111	1333	1556	1778	2000	2222	2667
16 x 22	2.44	24 x 30	32 x 38	9.5	978	1222	1467	1711	1956	2200	2444	2933
16 x 24	2.67	24 x 32	32 x 40	9.5	1067	1333	1600	1867	2133	2400	2667	3200
16 x 30	3.33	24 x 38	32 x 46	9.5	1333	1667	2000	2333	2667	3000	3333	4000
16 x 36	4.00	24 x 44	32 x 52	14	1600	2000	2400	2800	3200	3600	4000	4800
16 x 42	4.67	24 x 50	32 x 58	14	1867	2333	2800	3267	3733	4200	4667	5600
16 x 48	5.33	24 x 56	32 x 64	14	2133	2667	3200	3733	4267	4800	5333	6400
16 x 54	6.00	24 x 62	32 x 70	14	2400	3000	3600	4200	4800	5400	6000	7200
16 x 60	6.67	24 x 68	32 x 76	14	2667	3333	4000	4667	5333	6000	6667	8000
16 x 72	8.00	24 x 80	32 x 88	14	3200	4000	4800	5600	6400	7200	8000	9600
18 x 18	2.25	26 x 26	34 x 34	9.5	900	1125	1350	1575	1800	2025	2250	2700
18 x 20	2.50	26 x 28	34 x 36	9.5	1000	1250	1500	1750	2000	2250	2500	3000
18 x 22	2.75	26 x 30	34 x 38	9.5	1100	1375	1650	1925	2200	2475	2750	3300
18 x 24	3.00	26 x 32	34 x 40	9.5	1200	1500	1800	2100	2400	2700	3000	3600
18 x 30	3.75	26 x 38	34 x 46	14	1500	1875	2250	2625	3000	3375	3750	4500
18 x 36	4.50	26 x 44	34 x 52	14	1800	2250	2700	3150	3600	4050	4500	5400
18 x 42	5.25	26 x 50	34 x 58	14	2100	2625	3150	3675	4200	4725	5250	6300
18 x 48	6.00	26 x 56	34 x 64	14	2400	3000	3600	4200	4800	5400	6000	7200
18 x 54	6.75	26 x 62	34 x 72	14	2700	3375	4050	4725	5400	6075	6750	8100
18 x 60	7.50	26 x 68	34 x 76	14	3000	3750	4500	5250	6000	6750	7500	9000
18 x 72	9.00	26 x 80	34 x 88	14	3600	4500	5400	6300	7200	8100	9000	10800
20 x 20	2.78	28 x 28	36 x 36	9.5	1111	1389	1667	1944	2222	2500	2778	3333
20 x 22	3.06	28 x 30	36 x 38	9.5	1222	1528	1833	2139	2444	2750	3056	3667
20 x 24	3.33	28 x 32	36 x 40	9.5	1333	1667	2000	2333	2667	3000	3333	4000
20 x 30	4.17	28 x 38	36 x 46	14	1667	2083	2500	2917	3333	3750	4167	5000
20 x 36	5.00	28 x 44	36 x 52	14	2000	2500	3000	3500	4000	4500	5000	6000
20 x 42	5.83	28 x 50	36 x 58	14	2333	2917	3500	4083	4667	5250	5833	7000
20 x 48	6.67	28 x 56	36 x 64	14	2667	3333	4000	4667	5333	6000	6667	8000
20 x 54	7.50	28 x 62	36 x 70	14	3000	3750	4500	5250	6000	6750	7500	9000
20 x 60	8.33	28 x 68	36 x 76	14	3333	4167	5000	5833	6667	7500	8333	10000
20 x 72	10.00	28 x 80	36 x 88	14	4000	5000	6000	7000	8000	9000	10000	12000
20 x 78	10.83	28 x 86	36 x 94	14	4333	5417	6500	7583	8667	9750	10833	13000

Gravity Ventilators

Model: GL (Continued)

Dimensions (Inches)

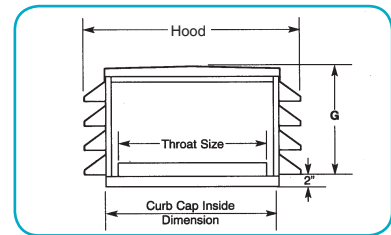

Performance Data (CFM)

Throat Size	Throat Area	Curb Cap	Hood A x B	G	INTAKE/THROAT VELOCITY (fpm)							
					400	500	600	700	800	900	1000	1200
24 x 24	4.00	32 x 32	40 x 40	14	1600	2000	2400	2800	3200	3600	4000	4800
24 x 30	5.00	32 x 38	40 x 46	14	2000	2500	3000	3500	4000	4500	5000	6000
24 x 36	6.00	32 x 44	40 x 52	14	2400	3000	3600	4200	4800	5400	6000	7200
24 x 42	7.00	32 x 50	40 x 58	14	2800	3500	4200	4900	5600	6300	7000	8400
24 x 48	8.00	32 x 56	40 x 64	14	3200	4000	4800	5600	6400	7200	8000	9600
24 x 54	9.00	32 x 62	40 x 70	14	3600	4500	5400	6300	7200	8100	9000	10800
24 x 60	10.00	32 x 68	40 x 76	14	4000	5000	6000	7000	8000	9000	10000	12000
24 x 66	11.00	32 x 74	40 x 82	14	4400	5500	6600	7700	8800	9900	11000	13200
24 x 72	12.00	32 x 80	40 x 88	14	4800	6000	7200	8400	9600	10800	12000	14400
24 x 78	13.00	32 x 86	40 x 94	14	5200	6500	7800	9100	10400	11700	13000	15600
24 x 84	14.00	32 x 92	40 x 100	14	5600	7000	8400	9800	11200	12600	14000	16800
30 x 30	6.25	38 x 38	46 x 46	14	2500	3125	3750	4375	5000	5625	6250	7500
30 x 36	7.50	38 x 44	46 x 52	14	3000	3750	4500	5250	6000	6750	7500	9000
30 x 42	8.75	38 x 50	46 x 58	14	3500	4375	5250	6125	7000	7875	8750	10500
30 x 48	10.00	38 x 56	46 x 64	14	4000	5000	6000	7000	8000	9000	10000	12000
30 x 54	11.25	38 x 62	46 x 70	18.5	4500	5625	6750	7875	9000	10125	11250	13500
30 x 60	12.50	38 x 68	46 x 76	18.5	5000	6250	7500	8750	10000	11250	12500	15000
30 x 66	13.75	38 x 74	46 x 82	18.5	5500	6875	8250	9625	11000	12375	13750	16500
30 x 72	15.00	38 x 80	46 x 88	18.5	6000	7500	9000	10500	12000	13500	15000	18000
30 x 78	16.25	38 x 86	46 x 94	18.5	6500	8125	9750	11375	13000	14625	16250	19500
30 x 84	17.50	38 x 92	46 x 100	18.5	7000	8750	10500	12250	14000	15750	17500	21000
36 x 36	9.00	44 x 44	52 x 52	14	3600	4500	5400	6300	7200	8100	9000	10800
36 x 42	10.50	44 x 50	52 x 58	18.5	4200	5250	6300	7350	8400	9450	10500	12600
36 x 48	12.00	44 x 56	52 x 64	18.5	4800	6000	7200	8400	9600	10800	12000	14400
36 x 54	13.50	44 x 62	52 x 70	18.5	5400	6750	8100	9450	10800	12150	13500	16200
36 x 60	15.00	44 x 68	52 x 76	18.5	6000	7500	9000	10500	12000	13500	15000	18000
36 x 66	16.50	44 x 74	52 x 82	18.5	6600	8250	9900	11550	13200	14850	16500	19800
36 x 72	18.00	44 x 80	52 x 88	18.5	7200	9000	10800	12600	14400	16200	18000	21600
36 x 78	19.50	44 x 86	52 x 94	18.5	7800	9750	11700	13850	15600	17550	19500	23400
36 x 84	21.00	44 x 92	52 x 100	18.5	8400	10500	12600	14700	16800	18900	21000	25200
42 x 42	12.25	50 x 50	58 x 58	18.5	4900	6125	7350	8575	9800	11025	12250	14700
42 x 48	14.00	50 x 56	58 x 64	18.5	5600	7000	8400	9800	11200	12600	14000	16800
42 x 54	15.75	50 x 62	58 x 70	18.5	6300	7875	9450	11025	12600	14175	15750	18900
42 x 60	17.50	50 x 68	58 x 76	18.5	7000	8750	10500	12250	14000	15750	17500	21000
42 x 66	19.25	50 x 74	58 x 82	18.5	7700	9625	11550	13475	15400	17325	19250	23100
42 x 72	21.00	50 x 80	58 x 88	18.5	8400	10500	12600	14700	16800	18900	21000	25200
42 x 78	22.75	50 x 86	58 x 94	23	9100	11375	13650	15925	18200	20475	22750	27300
42 x 84	24.50	50 x 92	58 x 100	23	9800	12250	14700	17150	19600	22050	24500	29400
48 x 48	16.00	56 x 56	64 x 64	18.5	6400	8000	9600	11200	12800	14400	16000	19200
48 x 54	18.00	56 x 62	64 x 70	18.5	7200	9000	10800	12600	14400	16200	18000	21600
48 x 60	20.00	56 x 68	64 x 76	18.5	8000	10000	12000	14000	16000	18000	20000	24000
48 x 66	22.00	56 x 74	64 x 82	23	8800	11000	13200	15400	17600	19800	22000	26400
48 x 72	24.00	56 x 80	64 x 88	23	9600	12000	14400	16800	19200	21600	24000	28800
48 x 78	26.00	56 x 86	64 x 94	23	10400	13000	15600	18200	20800	23400	26000	31200
48 x 84	28.00	56 x 92	64 x 100	23	11200	14000	16800	19600	22400	25200	28000	33600
54 x 54	20.25	62 x 62	70 x 70	23	8100	10125	12150	14175	16200	18225	20250	24300
54 x 60	22.50	62 x 68	70 x 76	23	9000	11250	13500	15750	18000	20250	22500	27000
54 x 66	24.75	62 x 74	70 x 82	23	9900	12375	14850	17325	19800	22275	24750	29700
54 x 72	27.00	62 x 80	70 x 88	23	10800	13500	16200	18900	21600	24300	27000	32400
54 x 78	29.25	62 x 86	70 x 94	23	11700	14625	17550	20475	23400	26325	29250	35100
54 x 84	31.50	62 x 92	70 x 100	23	12600	15750	18900	22050	25200	28350	31500	37800
60 x 60	25.00	68 x 68	76 x 76	23	10000	12500	15000	17500	20000	22500	25000	30000
60 x 66	27.50	68 x 74	76 x 82	23	11000	13750	16500	19250	22000	24750	27500	33000
60 x 72	30.00	68 x 80	76 x 88	23	12000	15000	18000	21000	24000	27000	30000	36000
60 x 84	35.00	68 x 92	76 x 100	27.5	14000	17500	21000	24500	28000	31500	35000	42000
66 x 66	30.25	74 x 74	82 x 82	23	12100	15125	18150	21175	24200	27225	30250	36300
66 x 72	33.00	74 x 80	82 x 88	23	13200	16500	19800	23100	26400	29700	33000	39600
66 x 78	35.75	74 x 86	82 x 94	27.5	14300	17875	21450	25025	28600	32175	35750	42900
66 x 84	38.50	74 x 92	82 x 100	27.5	15400	19250	23100	26950	30800	34650	38500	46200

Model GS - SPUN ALUMINUM INTAKE/EXHAUST VENTILATOR

The GSAA spun aluminum gravity ventilators feature an aluminum windband, curb cap with welded corners and integral birdscreen.

These hoods are designed for either intake or exhaust and feature a 1:1 intake/throat ratio. When used for intake applications, it should be sized using an approximate intake/throat velocity of 600 fpm or less to help prevent moisture entrainment through the hood.

Features

- Spun aluminum construction.
- Integral welded curb cap.
- Integral birdscreen.

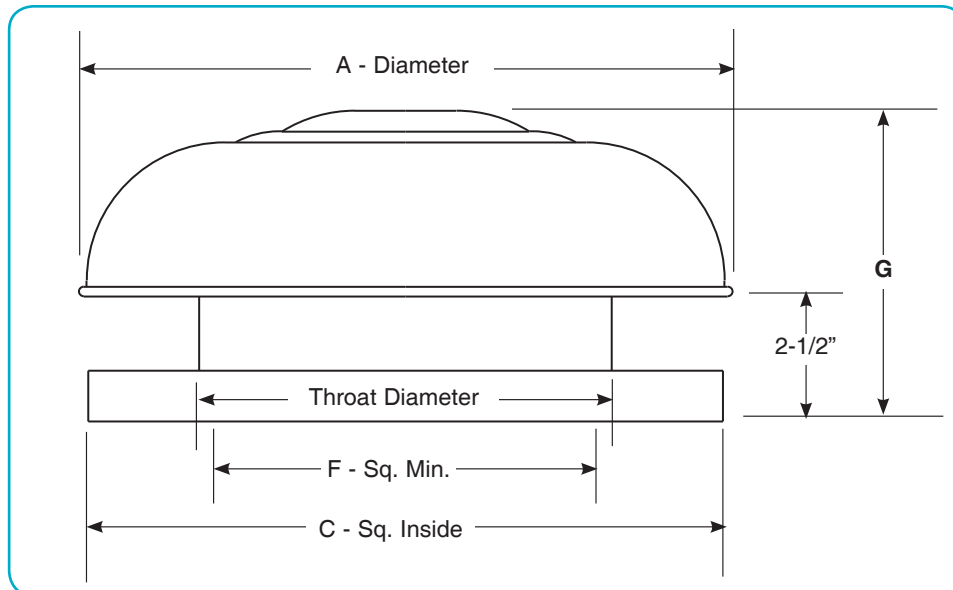
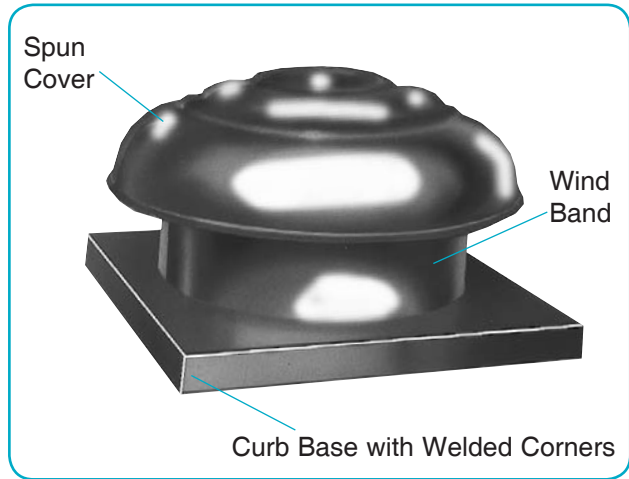

DIMENSIONS GS

Performance Data (CFM)

Model GSAA	Throat Dia.	Throat Area	Inlet Area	A	G	C	F	INTAKE/THROAT VELOCITY (FPM)							
								400	500	600	700	800	900	1000	1200
12	13¼	.96	1.62	21¾	8⅞	20½	16	385	480	575	670	770	870	960	1150
16	16¼	1.44	2.23	25¾	10¼	25	20	555	695	835	975	1115	1250	1390	1670
22	22	2.64	3.34	33⅞	12¼	28½	24	1055	1320	1580	1845	2110	2370	2640	3170
28	28¾	4.51	5.23	42¼	13⅝	37	32	1805	2250	2700	3155	3600	4055	4510	5410
32	32	5.58	8.19	50¼	18⅞	43	38	2230	2790	3350	3905	4465	5020	5580	6695
38	38	7.87	10.16	57½	21⅞	49	44	3150	3935	4720	5510	6295	7085	7870	9445
46	46	11.54	13.86	68¼	25½	57	52	4615	5770	6925	8080	9230	10385	11540	13850
52	52	14.75	18.86	78½	30¼	57	52	5900	7375	8850	10325	11800	13275	14750	17700
60	60	19.64	19.64	84¾	32¼	67	62	7855	9820	11785	13750	15710	17675	19640	23570

Intake selections in Bold Color will result in hood velocities in excess of 600 FPM.

Model VXCA - SPUN ALUMINUM ROOF CAP INTAKE/EXHAUST APPLICATIONS

Model VXCA spun aluminum roof caps feature all aluminum construction with an integral, stamped birdscreen and either a curb cap (VXCAC) or a self-flashing base (VXCAF).

These caps are designed for either intake or exhaust applications. For intake applications, these caps should be sized using an appropriate intake velocity of 500 fpm or less to prevent moisture entrainment through the hood.

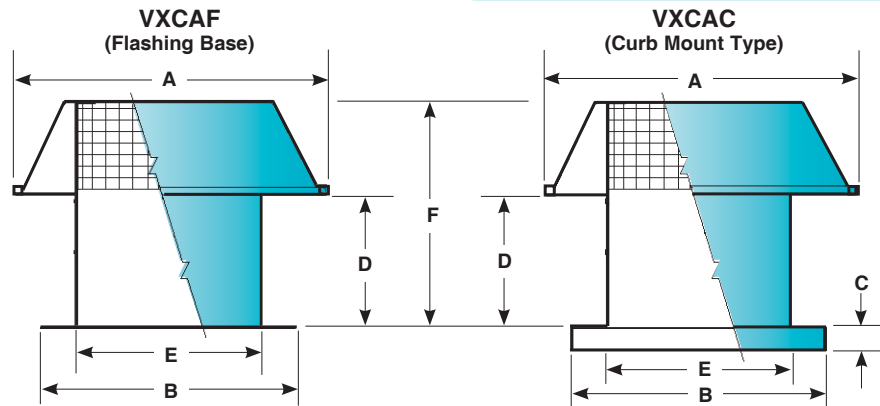

DIMENSIONS (Listed in Inches)							
Roof Cap Size	A Dia.	B Sq.	C	D	E Dia.	F	Curb Size
VXCAF 08	11	15	—	7-5/8	8-1/8	10-1/8	—
VXCAC 08	11	15-1/2	1-7/8	7-5/8	8-1/8	10-1/8	14x14
VXCAF 12	18-1/2	20	—	11-1/8	12	15-5/8	—
VXCAC 12	18-1/2	17-3/4	1-7/8	11-1/8	12	15-5/8	16x16
VXCAF 16	26	24	—	11-1/2	16	18-1/2	—
VXCAC 16	26	22	1-7/8	11-1/2	16	18-1/2	20-1/2x20-1/2
VXCAF 20	32	28	—	9-1/2	20	19-3/4	—
VXCAC 20	32	26	1-7/8	9-1/2	20	19-3/4	24-1/2x24x1/2

VXCAF08 & VXCAC08

AIRFLOW PERFORMANCE

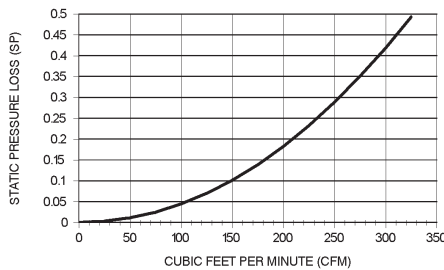

VXCAF12 & VXCAC12

AIRFLOW PERFORMANCE

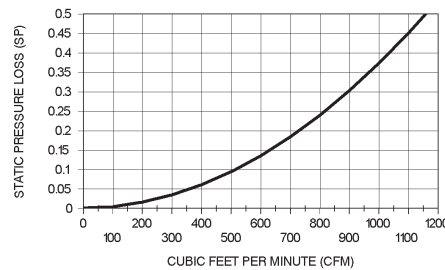

VXCAF16 & VXCAC16

AIRFLOW PERFORMANCE

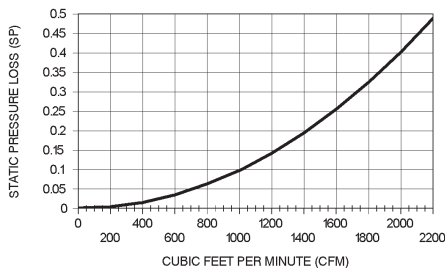

VXCAF20 & VXCAC20

AIRFLOW PERFORMANCE

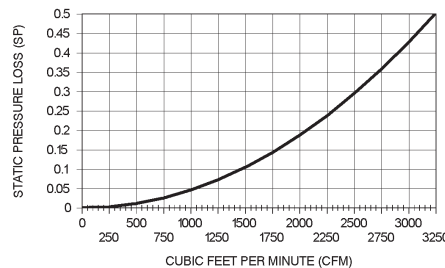

Air flow performance shown is static pressure drop for roof cap with inlet duct at standard air density. Test methods per ANSI/AMCA Standard 210-85 and ANSI/ASHRAE Standard 51-1985 were conducted in an AMCA Registered Laboratory.

1. Determine Required Throat Area.

$$\text{Throat Area (Sq. Ft.)} = \frac{\text{Design CFM}}{\text{Throat Velocity}}$$

To insure minimum moisture entrainment in intake applications, select inlet velocities of 500 FPM or less. Inlet velocities are shown in the performance table for each series.

2. Establish Optimum Pressure Drop.

Refer to graphs shown below to establish allowable pressure drop depending on fan requirements or pressure to be relieved and selected throat velocity. In non-ducted systems, velocity pressure should be added to establish total pressure drop.

$$P_t = P_s + P_v$$

To calculate velocity pressure, use the following formula.

$$\text{Velocity Pressure} = \left[\frac{\text{Throat Velocity}}{4005} \right]^2$$

Exhaust situations operating on temperatures differential only and without building pressurization will operate at approximately .05 inches P_t .

3. Select the appropriate unit size from performance shown for each series.

Static Pressure Drop

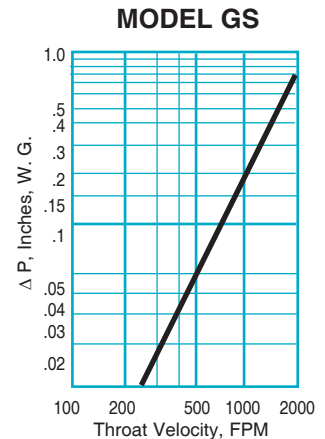
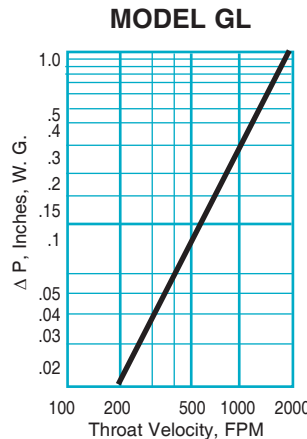
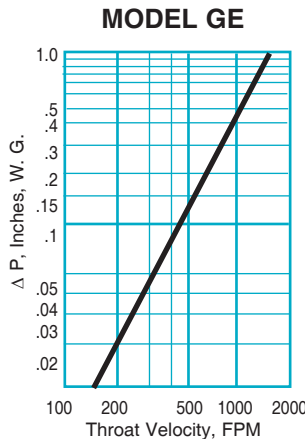
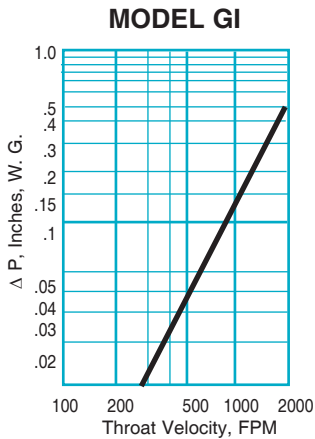

Throat Area Table

		WIDTH														
		12	14	16	18	20	22	24	30	36	42	48	54	60	66	72
LENGTH	12	1.00														
	14	1.17	1.36													
	16	1.33	1.56	1.78												
	18	1.50	1.75	2.00	2.25											
	20	1.67	1.94	2.22	2.50	2.78										
	22	1.83	2.14	2.44	2.75	3.06	3.36									
	24	2.00	2.33	2.67	3.00	3.33	3.67	4.00								
	30	2.50	2.92	3.33	3.75	4.17	4.58	5.00	6.25							
	36	3.00	3.50	4.00	4.50	5.00	5.50	6.00	7.50	9.00						
	42	3.50	4.08	4.67	5.25	5.83	6.42	7.00	8.75	10.50	12.25					
	48	4.00	4.67	5.33	6.00	6.67	7.33	8.00	10.00	12.00	14.00	16.00				
	54			6.00	6.75	7.50	8.25	9.00	11.25	13.50	15.75	18.00	20.25			
	60				7.50	8.33	9.17	10.00	12.50	15.00	17.50	20.00	22.50	25.00		
66				8.25	9.17	10.08	11.00	13.75	16.50	19.25	22.00	24.75	27.50	30.25		
72					10.00	11.00	12.00	15.00	18.00	21.00	24.00	27.00	30.00	33.00	36.00	
84					11.67	12.83	14.00	17.50	21.00	24.50	28.00	31.50	35.00	38.50	42.00	
96						14.67	16.00	20.00	24.00	28.00	32.00	36.00	40.00	44.00	48.00	
108								22.50	27.00	31.50	36.00	40.50	45.00	49.50	54.00	
120								25.00	30.00	35.00	40.00	45.00	50.00	55.00	60.00	

AREA IN SQUARE FEET

ACCESSORIES

ROOF CURBS

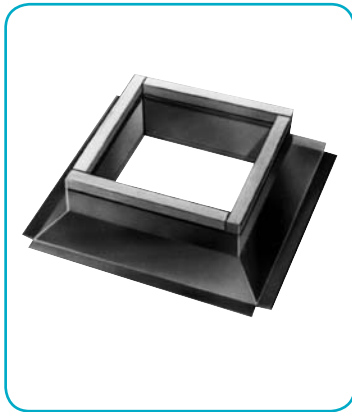

Roof curb Models JCFAAG galvanized and JCFAA aluminum are of welded construction with 1-1/2" fiberglass insulation and wood nailer. Standard heights are 8" and 12" with custom heights available.

Pitched curbs are available with standard cant for minor slopes (to approximately 1-1/2" per ft.) or "self-flashing" wide flange without cant for steeper pitches.

Roof curb modifications include a metal liner to prevent contamination of the insulation, raised cant for use with insulated roof decks and damper shelf to support a backdraft damper inside the curb.

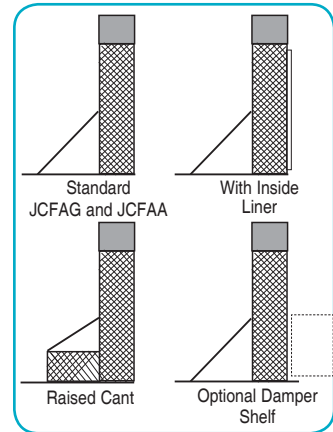

BACKDRAFT DAMPERS

Carnes Model JDHAA automatic gravity dampers are available to prevent backflow. Damper frames are heavy-duty box type. Blades are aluminum with felt edges and are linked together for quiet operation. A counterbalance spring is adjustable for tension to provide minimum resistance to air flow.

Motorized operation (JDHAM) may be provided by adding the motor pack available for 115 and 230 volt operation. Transformers are available for 460 and 560 volt operation.



OPTIONS

Hinged covers on curb caps, insulated covers, filter racks and birdscreens.

CONSTRUCTION OPTIONS

GI & GE units are available with a pitched roof option, this option is best suited in areas where excessive snow load is a concern or it is more architecturally suitable.

