

CARNES COMPANY 448 S. Main St., P. O. Box 930040, Verona, WI 53593-0040 Phone: (608)845-6411 Fax: (608)845-6504 www.carnes.com

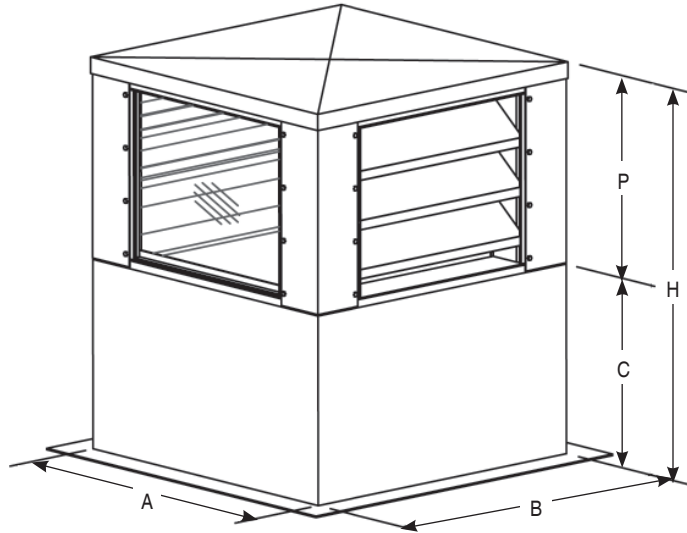

### Model PEAB Standard Specifications

**Blades:** 6063-T6 extruded aluminum with .081" (2.1 mm) thickness.

**Roof:** Fabricated at .090" (2.3 mm) thickness 3003-H14 formed aluminum, roof is cross broken for adequate element run-off and is attached with sheet metal screws for ease in removal.

**Framing:** 1-1/2" x 1-1/2" x 1/8" (38 mm x 38 mm) framing angles of 6063-T6 extruded aluminum.

**Penthouse Finish:** all aluminum mill finish for low maintenance and resistance to corrosion

**Curb:** 12 ga. galvanized steel, 3" mounting flange, welded construction mill finish (standard). Other gauges and flange widths available, consult factory.

**Post Corner:** .090" (2.3 mm) thickness 3003-H14 formed aluminum

**Glass:** .125" annealed (clear)

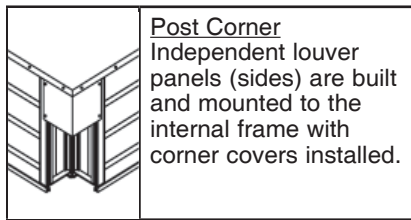

**Post Corner**  
Independent louver panels (sides) are built and mounted to the internal frame with corner covers installed.

A = 38"  
B = 38"  
C = 12", 24" or 36"  
P = 18"

### Options:

- Smoke Damper (Model ESWA or ETWA)
  - Class I                       Class II
  - Position Indicator For Actuator (Model PXPA)
- Actuator Voltage
  - 120V                       24V
- Insect Screen (18-16 Mesh)
- Other Screens (Specify) \_\_\_\_\_
- Special Finish \_\_\_\_\_
- Anti-Condensate Coating
- 1" Fiberglass Insulation

Tag	Qty.	Size			Variations
		Width	Length	Height	

**Project**  
**Arch./Engr.**  
**Representative**

**Location**  
**Contractor**  
**Date**

# Model PEAB Details

