

**READ AND SAVE
THESE INSTRUCTIONS**

CARNES®

COMMERCIAL HUMIDISTAT

OWNERS MANUAL AND QUICK REFERENCE GUIDE

**MODELS
HXHAS, HXHASt,
HXHAW, HXHAWT**



FORM 16767
ISSUED: 03-10-21



CAUTION:

Follow all recommendations, instructions and precautions in this Installation, Operation and Maintenance Manual to maximize performance, maintain efficiency and to provide a safe operational environment. Do not install, use or operate this equipment until this manual has been completely read and understood.

Important Note: Disconnect electrical power to the furnace and humidifier before servicing or starting installation.

Liability:

Carnes does not accept any liability for installations of humidifier equipment installed by unqualified personnel, or the use of parts, components, equipment, or alterations of Carnes manufactured equipment that is not authorized or approved by Carnes.

COMMERCIAL HUMIDISTAT | Table of Contents

Models HXHAS, HXHAST, HXHAW, HXHAWT	0
Caution.....	2
Packing List.....	4
Humidistat Function	5
Complete Installation	6
Duct Installation.....	6
Wall Mount Installation	7
Outdoor Temperature Sensor	8
Location Outdoors.....	9
Location in Outdoor Air Intake	10
Wiring	11
Power Connection Wiring (R, C)	12
Outdoor Temperature Sensor Wiring (ODT)	12
Humidifier Control Wiring (H1+).....	12
Modes of Operation	13
Humidistat Demand Mode.....	14
High Limit Humidistat	15
Humidity Sensor	15
Operation	16
Screen and Menu	16
Home Screen	16
Settings Page.....	17
Setpoint Adjustment Page	17
Units Option	18

Packing List | COMMERCIAL HUMIDISTAT

Verify all components were included in the humidistat packaging.

HXHAW	A. Humidistat E. Drywall Anchors and Screws (2 each)
HXHAWT	A. Humidistat C. Outdoor Air Temperature Sensor E. Drywall Anchors and Screws (2 each)
HXHAS	A. Humidistat B. Duct Sensor D. Sheet Metal Screws (3) E. Drywall Anchors and Screws (2 each)
HXHASt	A. Humidistat B. Duct Sensor C. Outdoor Air Temperature Sensor D. Sheet Metal Screws (3) E. Drywall Anchors and Screws (2 each)

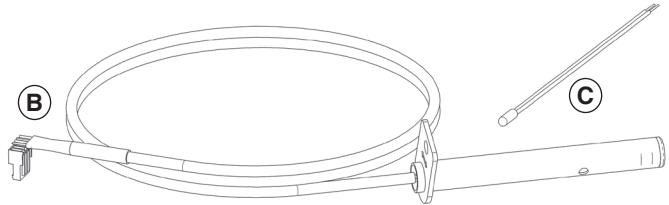
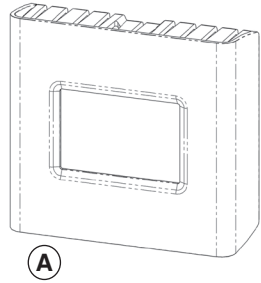

Figure 1: Humidistat Package Components

Humidistat Function

A humidistat is a device that measures relative humidity and works with an external controller or humidifier to automatically control the humidifier to maintain a desired humidity level throughout the conditioned space.

The Carnes commercial humidistats are capable of controlling a humidifier by ON/OFF or modulating 0-10 VDC control signals. The commercial humidistat package offers 2 types of installation and multiple modes of operation to fit any humidification need. The two types of installations are wall-mounted and duct-mounted and are offered in differing packages upon ordering. The multiple modes of operation are the industry standard humidistat demand output, the high limit demand output, and the humidity sensor output.

Each type of the commercial humidistat will be shipped with different defaults, all listed below...

Humidistat Version	Output (Default)	Mode (Default)
HXHAS	Modulating 0-10 VDC	Common Demand Signal
HXHAST	Modulating 0-10 VDC	Common Demand Signal
HXHAW	Modulating 0-10 VDC	High Limit Demand Signal
HXHAWT	Modulating 0-10 VDC	High Limit Demand Signal

Duct Mounted Installation

1. Choose a location in the duct that is downstream of the humidifier steam distribution unit. Make sure the humidistat mounting location is close enough to plug in the sensor. **Install the sensor a minimum of 6” ahead of or a minimum 15” after a change in air flow direction or obstruction in the duct. Do not install duct sensor near outdoor air intake.**
2. Drill a 1/2” holes in the duct to place the sensor. Use a sheet metal screw (D) to attach the sensor to the duct. Arrows in the duct mount sensor indicate the direction the air flow should pass over the sensor for optimal measurements.
3. Mount the humidistat display to a wall or duct in a convenient location that allows easy adjustment to the settings. To mount the humidistat, remove the back plate and install with screws (D or E) through the mounting holes.
4. **CAUTION:** do not plug or un-plug the duct sensor with power applied to the humidistat, the humidity sensor will break. Plug the duct sensor into the humidistat. Pay close attention to the orientation of the plug or permanent damage will occur to the sensor. See *Figure 3* for proper orientation of the duct sensor plug. Place the hook of the red plug up and away from the humidistat display board and push onto the white connector located in the bottom left corner of the humidistat display board. The wire colors also market on the circuit board and match the correct orientation of the plug wires.

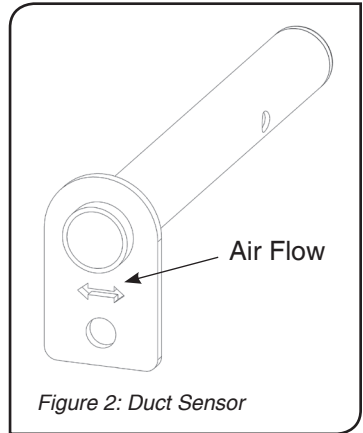
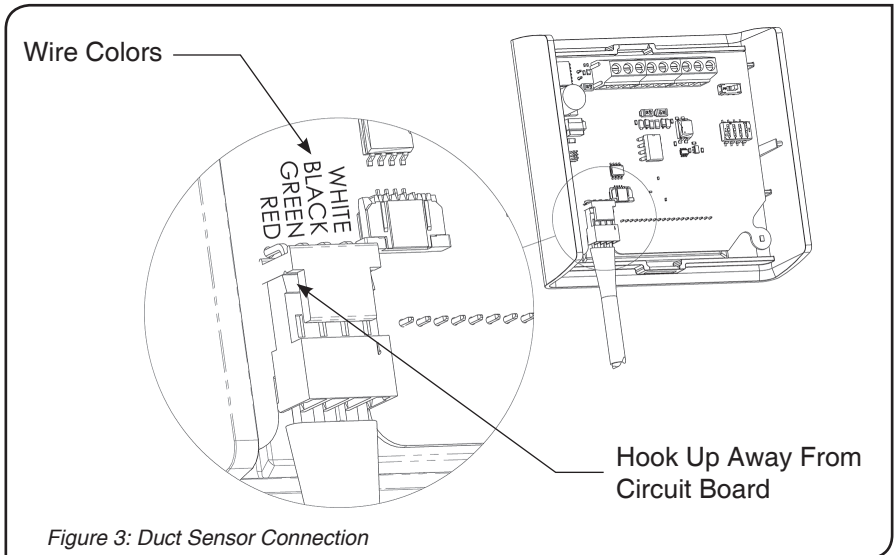

Figure 2: Duct Sensor

CAUTION: Turn off power before plugging or un-plugging duct sensor. Do not plug or un-plug the duct sensor with power applied to the humidistat, the sensor will break.



Wall Mount Installation

1. Select a location in the space that requires humidity control. Typically, the humidistat will be placed in a location with reasonable air flow for accurate environmental measurements.
2. The humidistat should be placed in an area of sufficient air movement and out of the way of any other temperature or humidity affects. For example, do not place the humidistat in direct sunlight, near windows, or near an air register.
3. Once the location is selected, attach the humidistat back cover to the wall using 2 screws/anchors (E).

Note: The duct sensor is not needed for this installation option.

Outdoor Air Temperature Sensor Installation

When outdoor air temperature is very low, condensation can occur on windows and other surfaces which may cause damage to the structure. To minimize this risk, the outdoor air temperature sensor should be installed. The outdoor air temperature lowers the humidity setpoint to a safe level, where the indoor relative humidity is too low to condense. The outdoor temperature compensation control adjusts the maximum humidity setpoint according to the values shown in Table 1. The humidistat will automatically detect if the outdoor air temperature sensor is connected and control the relative humidity setpoint accordingly.

Table 1: Maximum setpoint based on outdoor air temperature

Outdoor Air Temperature (°F)	Outdoor Air Temperature (°C)	Adjusted Maximum Humidity Setpoint (RH%)
-30	-34.4	10
-20	-28.9	15
-10	-23.3	20
0	-17.8	25
10	-12.2	30
20	-6.7	35
30	-1.1	40
40	4.4	45
45	7.2	47.5
>45	>7.2	Unadjusted

CAUTION: electrical interference can cause erratic system operation.

- Do not route temperature sensor wiring with building power wiring, next to control contactors, near light dimming circuits, or electric motors.
- Use shielded cable to reduce interference when rerouting is not possible.
- Be sure wires have a cable separate from the humidistat cable.
- See *Figure 5* for wiring diagram.

Exterior Wall Installation

To mount the Outdoor Temperature Sensor outdoors the signal wire will need to penetrate an exterior wall. Use the following guidelines for proper operation of the sensor:

Mount the sensor where:

- there is good air circulation
- wire distance between sensor and humidistat is less than 200 feet
- it can measure true outdoor ambient air temperature
- it is above the expected snow line

Do NOT mount the sensor:

- in direct sun
- where it may be covered by debris, snow, or ice

Outdoor Air Intake Duct Installation

Mount the sensor in an outdoor air intake by drilling a ¼ inch hole within 8 inches of outside. Angle the hole towards the outside. Insert the temperature sensor into the intake pipe until the sensor is at least 2 inches outside the structure in the intake pipe. Seal the hole and secure the wire so it cannot be accidentally pulled out.

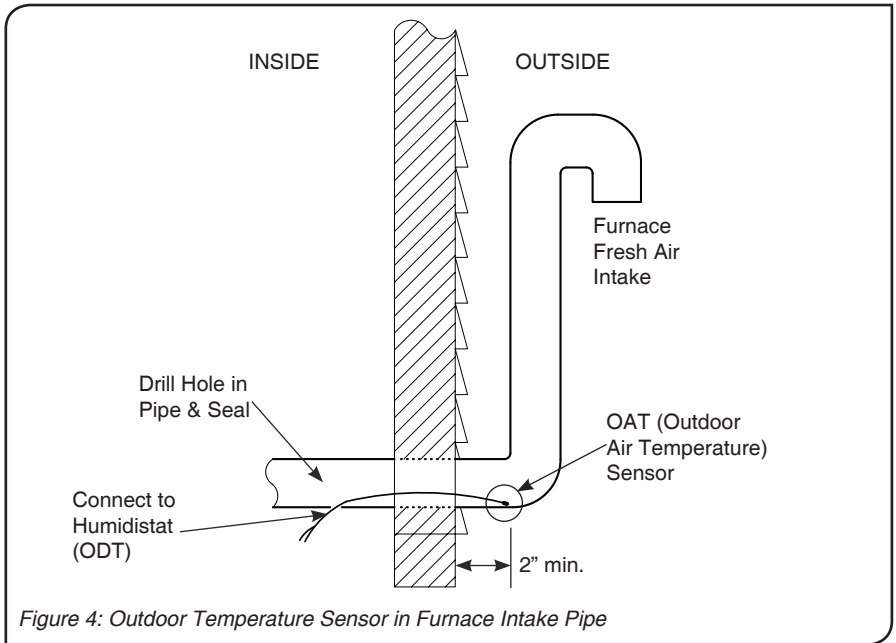

Installation | COMMERCIAL HUMIDISTAT

Power Connection Wiring (R, C)

The humidistat controller power connections are R and C and will most commonly be powered by the 18VDC supply directly from the humidifier control board. Proper R and C wiring is shown in *Figure 5*.

Outdoor Temperature Sensor Wiring (ODT):

The outdoor temperature sensor wires will connect into the ODT terminals on the humidistat terminal block as shown in *Figure 5*.

Humidifier Control Wiring (H1+):

The humidifier control terminal is labeled on the humidistat terminal block as H1+. This terminal will need to be wired directly to the humidifier as shown in *Figure 5*. H1+ on the humidistat will connect to either the 'HUM' input or the 'HI' input on the humidifier control board, depending on the configuration of the humidistat. The 'HUM' input will be used when using the humidistat as a standard humidistat or humidity sensor and the 'HI' input will be used when using the humidistat as a high limit humidistat.

Modes

The Carnes universal humidistat will come set up in the pre-designated configuration but has the ability to change and operate in different control modes depending on the application. The modes are set by toggling DIP-switches located on the back of the main humidistat display board, shown in *Figure 6*.

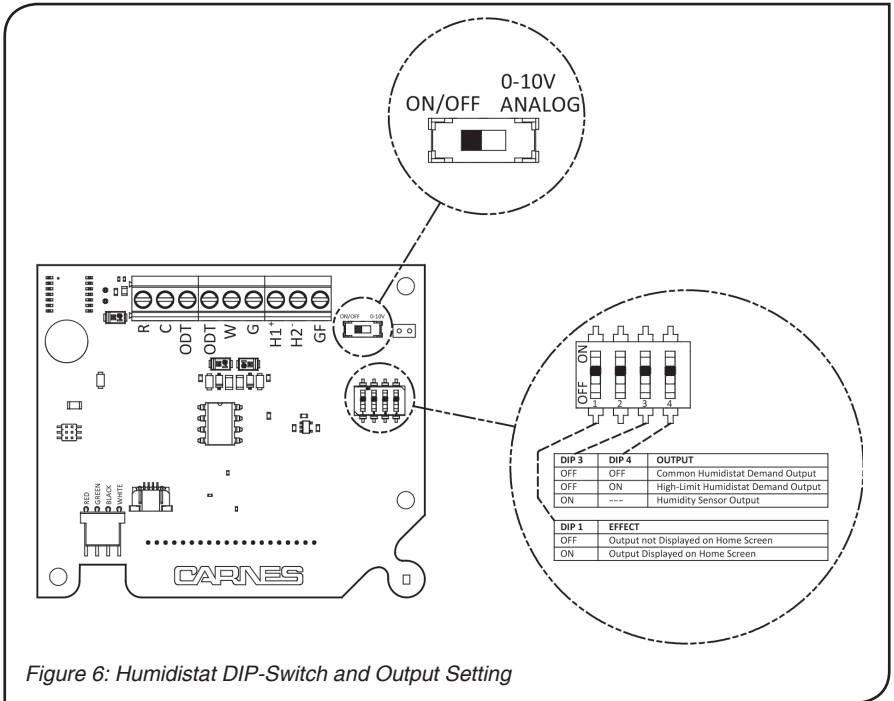

Figure 6: Humidistat DIP-Switch and Output Setting

Humidistat Demand Mode

In the humidistat demand mode, the humidistat will measure the relative humidity of the space, compare the measured value with the setpoint, and output a demand signal to the humidifier. The demand signal in this mode can be either on/off or a modulating 0-10VDC. When measured humidity is 3%RH above the setpoint, the demand signal will be zero. When measured humidity reaches 3%RH below the setpoint the demand signal will be 100%.

The modulating 0-10VDC humidistat output corresponds to the demand with 0VDC at 0% demand and 10VDC at 100% demand. The ON/OFF humidistat output will turn on at 100% demand and will turn back off at 0% demand.

High Limit Humidistat

In the high limit humidistat mode the humidistat will measure the relative humidity of the space, compare the measured value with a high-set setpoint, and output a demand signal to the humidifier. The demand signal in this mode can be either ON/OFF or a modulating 0-10VDC signal. If the measured humidity is greater than the high-set setpoint, the demand signal will be zero, and if the measured humidity reaches 10% below the setpoint the demand signal will be 100%. The ON/OFF signal will turn on when the measured humidity is 10% below the setpoint and will back off when the measured humidity is greater than the setpoint. The high limit humidistat typically works in conjunction with a wall humidistat to prevent duct work from becoming saturated by reducing the humidifier output when high-humidity levels are reached.

Humidity Sensor

In humidity sensor mode the humidistat module will measure the relative humidity of the space and output a 0-10VDC signal corresponding directly with the measured humidity (0%RH = 0VDC, 100%RH = 10VDC). This mode can be utilized when the Carnes humidifier has been configured to function using a humidity sensor and not a common humidistat. Utilizing the humidistat and humidifier in this way allows for the user to set the setpoint at the humidifier and not the humidistat. This is the preferred operation for BACnet enabled humidifiers.

Screens and Menu

Home Screen

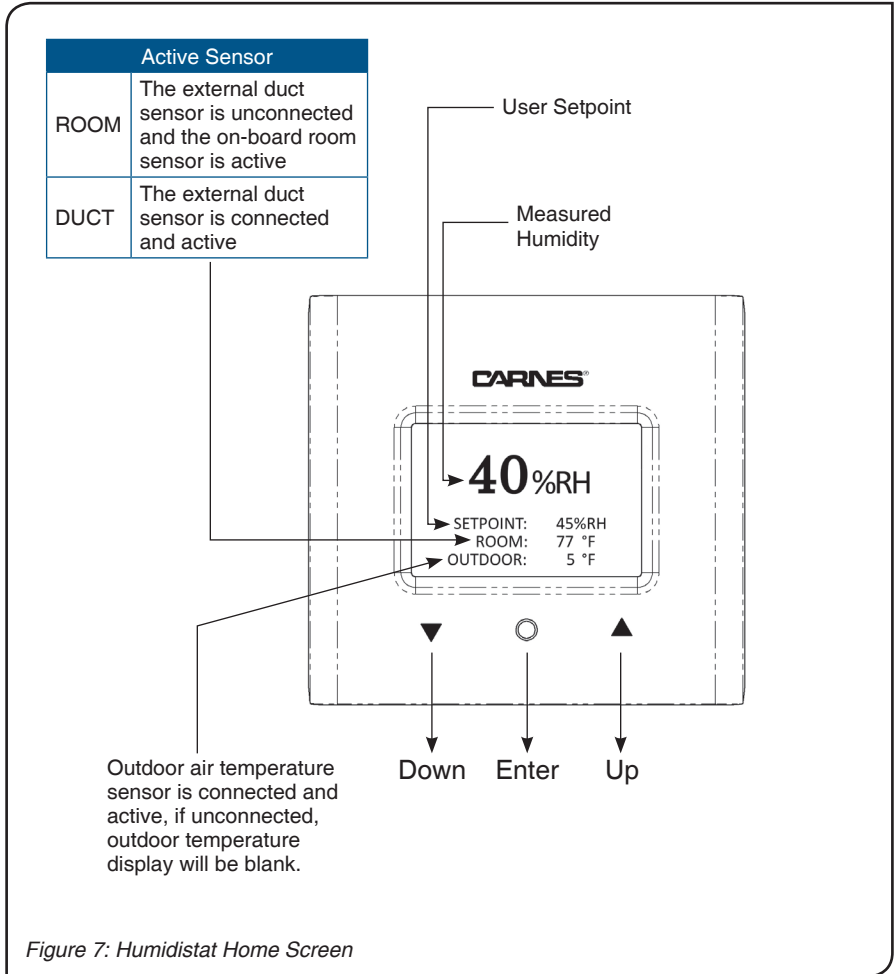

Settings Page

From the Settings page the user can select and adjust how they would like their humidistat to operate. Pressing Enter while on the BACK selection will take the user back to the previous page.

Pressing the Enter button once will bring up a settings screen with user selectable options. Use the Up/Down buttons to navigate the menu and the Enter button to select and confirm an option.

Setpoint Adjustment Page

While on the Setpoint Adjustment Page the user can adjust the desired relative humidity setpoint for the humidified space, shown in *Figure 8*. The factory default value of this setting is 45%RH and can be adjusted up or down depending on the user preference. To save the value press the enter button again. The new humidity setpoint should now be shown on the main screen (*Figure 7*).

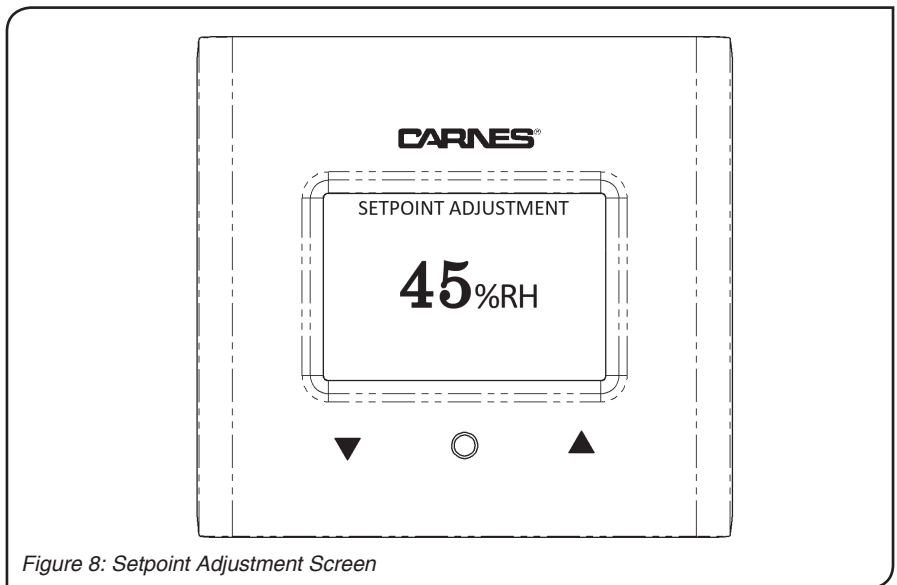

Figure 8: Setpoint Adjustment Screen

Units Option | COMMERCIAL HUMIDISTAT

Units Option

The Units option allows the user to select temperature display units in Fahrenheit or Celsius. Fahrenheit is the default.



This device complies with part 15 of the FCC Rules. Operation is subject to the following two conditions: (1) This device may not cause harmful interference, and (2) this device must accept any interference received, including interference that may cause undesired operation.

CARNES[®]

448 S. Main St., PO Box 930040, Verona, WI 53593-0040
Phone: 608\845-6411 | Fax: 608\845-6504 | www.carnes.com